



M30 BBRight BB

SAFETY INFORMATION - READ BEFORE RIDE

Since specific tools and experience are necessary for proper installation, it is recommended that the product be installed by a qualified bicycle technician.

Read the service instructions of your crank carefully prior to installing the parts. Loose, worn or damaged parts may cause riding problems and serious injury may occur as a result. If installation and adjustments are not carried out correctly, the chain may come off and this may cause you to fall off the bicycle which could result in serious injury. **Read these instructions carefully, and keep them for later use.**

- Ensure that your frame shell is clean. Remove any c-clips/bearings so frame shell is empty.
- Before riding the bicycle, check that there is no play or looseness in the bottom bracket connection. Also, be sure to retighten the crankarms and pedals at periodic intervals.
- If you feel any looseness or 'play' in the bearings, the bottom bracket should be inspected/replaced.
- Be sure to read the instructions for your front chainrings/crank in conjunction with these service instructions.
- **Do not wash the bottom bracket with high-pressure jets of water.**
- For maximum performance it is required to remove and periodically inspect/clean your Praxis Works bottom bracket.
- **Parts are not guaranteed against natural wear or deterioration resulting from normal use.**
- For any questions regarding methods of installation, adjustment, maintenance or operation, please contact a professional bicycle dealer or call Praxis Works.
- Praxis Works assumes no responsibility for damages or injury related to improperly installed components.

READ THE STEP BY STEP INSTRUCTIONS PROVIDED ON THE OTHER SIDE.

WARRANTY

- Praxis Works Bottom Bracket products are warranted to be free from defects in materials or workmanship for two years after original purchase. The warranty is non-transferable and valid to the original purchaser of the product only.
- Any attempt to modify the product in any way such as drilling, grinding or painting will void the warranty.
- This warranty is not valid for "abused" or neglected products, or products that are damaged by improper installation.
- If a defect is found, our entire liability and your sole remedy shall be, at our option, free repair or replacement of the Praxis product.
- Except as expressly required by law, Praxis Works shall not be held liable for any indirect, special, or consequential damages.

THIS WRITTEN EXPRESS WARRANTY IS IN LIEU OF ALL OTHER WARRANTIES, IMPLIED OR EXPRESSED. This warranty gives you specific legal rights, and you may also have other rights which vary state to state. **For more information on warranty policy and instructions for completing a warranty claim, check out the Full Warranty Policy found at our website. www.praxis-works.com**

M30 BBRight Road BB - BB Compatibility and Spec

CRANKSET	Compatible with Praxis M30 ROAD Cranksets
FRAME SHELL	Only for PF BBRight frames
FRONT DERAILLEUR	Braze-on, Clamp-on, or Direct Mount

REQUIRED TOOLS

- Press Tool
- M30 BB Socket Tool
- M30 BB Wrench
- One 3/8" Drive Ratchet
- Headset cup removal tool
- Anti-Seize Compound
- Waterproof Grease

Included Parts

Number	Part	Qty
1.	28mm ID X 2mm Dust Cover (Stepped Cover)	1
2.	LEFT/NON-DRIVE Cup 28mm ID Bearing	1
3.	Delrin PF Sleeve	1
4.	Orange Rubber Collet	1
5.	Black Plastic Compression sleeve	1
6.	RIGHT/DRIVE Cup 30mm ID Bearing	1
7.	30mm ID X 1mm Dust Cover	1
8.	30mm ID X 2mm Dust Cover	1
9.	30mm ID X 3mm Dust Cover	1
10.	Wave Washer	1

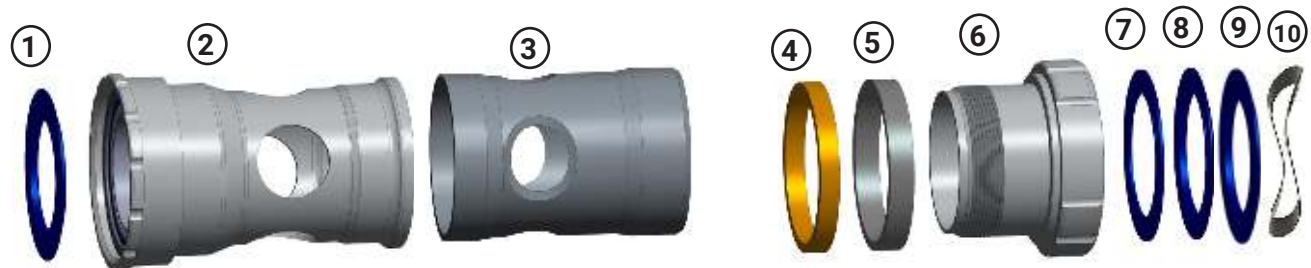

LEFT/NON-DRIVE
28mm I.D

RIGHT/DRIVE
30mm I.D

BB CUP PREPARATION

NON-DRIVE/LEFT CUP

- 1 DO NOT remove the included PF sleeve on this cup. This sleeve must be on the BB for correct installation

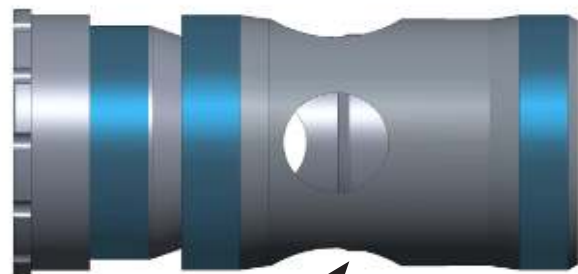

PF SLEEVE

- 2 Grease both ends of the PF sleeve contact surfaces

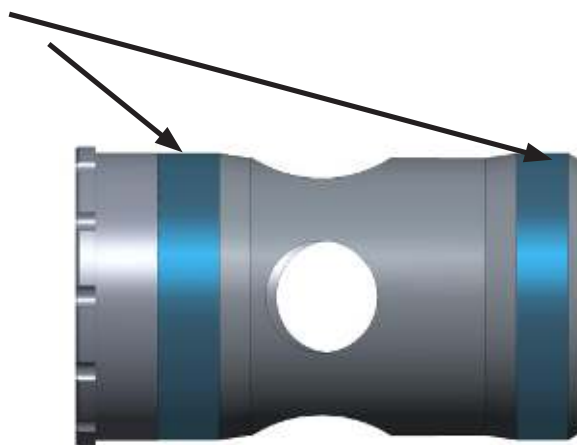

DRIVE/RIGHT CUP

- 1 Slide the Black Plastic Sleeve and then the Orange Rubber Collet onto the cup. This is critical to the function of your BB
- 2 Apply thin coating of **anti-seize** to the Right/Drive cup threads
- 3 Apply thin coating of **grease** to the outside of the Orange Rubber Collet and Black Plastic Sleeve

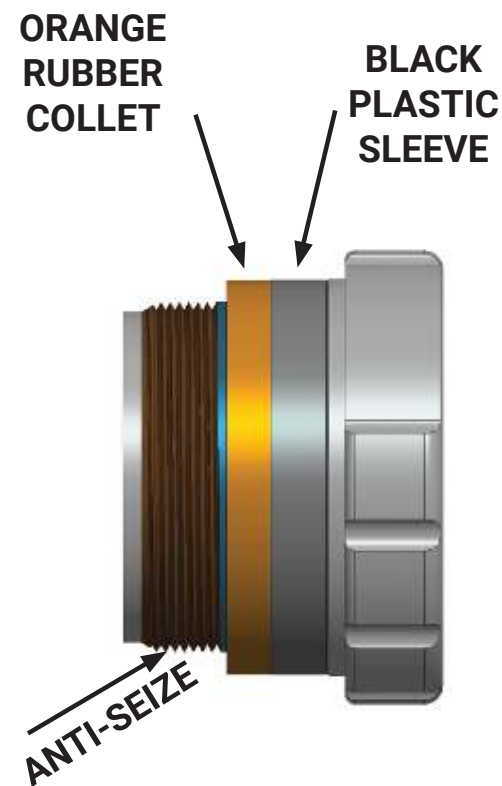

Next page *INSTALLATION*.....

BOTTOM BRACKET INSTALLATION

- 1 With a press tool, GENTLY press the Left/Non-Drive cup into the Left/Non-Drive side of frame. The edge of the BB should just BARELY touch the bike frame
- 2 Start threading the **Right/Drive Cup** in **CLOCKWISE** with your M30 BB tool. As it threads in, you will feel friction build as the Orange Rubber Collet expands inside the frame. **This is normal. TURN Right/Drive Cup UNTIL IT STOPS, but do not fully tighten**

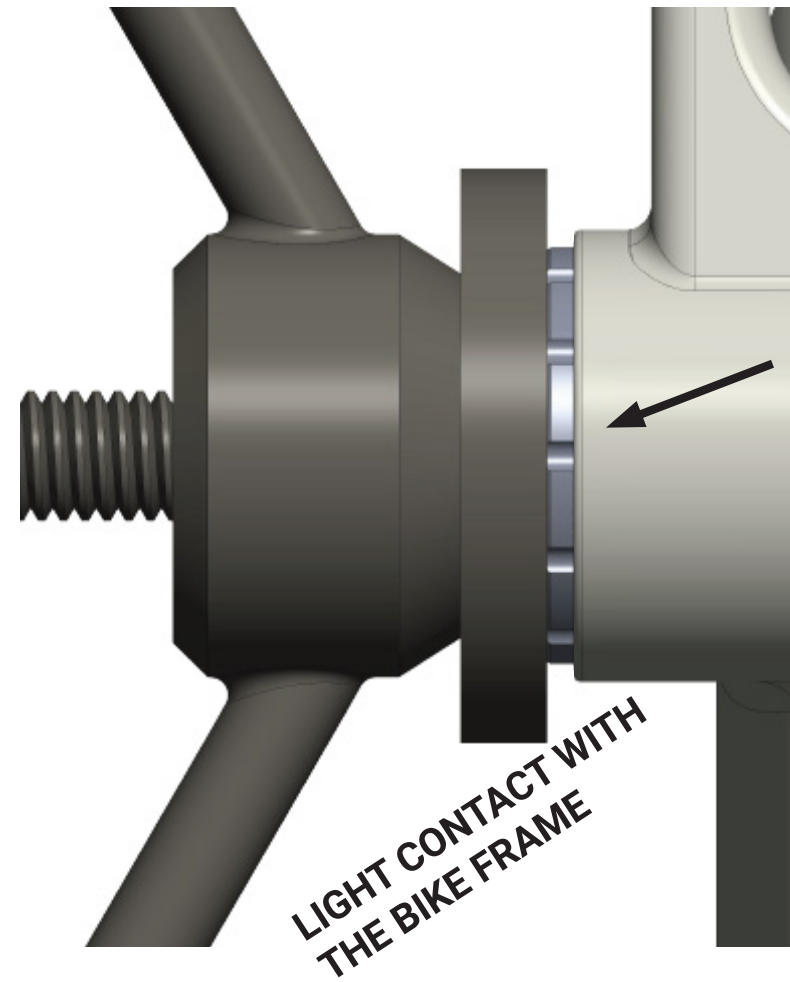
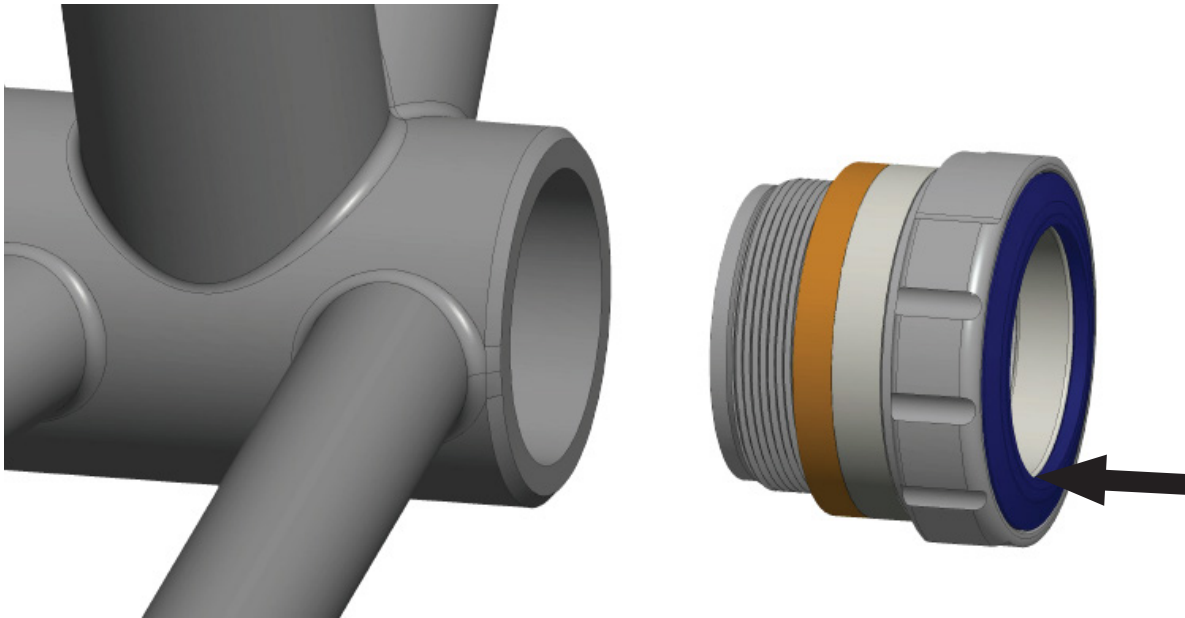

INSTALLATION continued next page...

3



With 2nd M30 BB tool, hold Left/Non-Drive Cup in place while you tighten Drive cup fully. The 2nd tool gives you leverage so you feel when the Drive cup bottoms out on the Non-Drive cup

*The Drive Cup has a machined stop and by design it **MUST** be tightened until it bottoms out on the Non-Drive cup. This precisely sets/stops the Collet expansion*

4

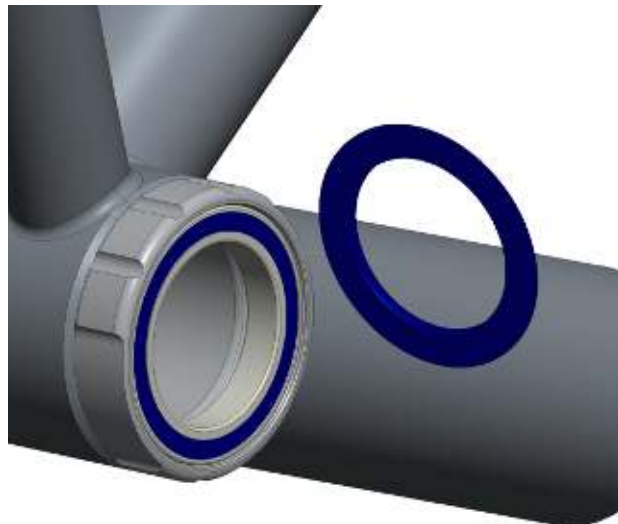

See next page to find correct Dust Covers for your crank. Lightly grease underside of Dust Covers and place them over bearings **with Praxis logos facing outward**. Now you can install the crank

BB REMOVAL

1 Unscrew the Right/Drive Cup **COUNTER-CLOCKWISE** and remove. **Use one tool to hold the Left side for leverage, and the other to unscrew the Drive cup**

2 Once the Drive Cup is removed, slide a headset cup removal tool through from the drive side and it **will catch outside edge of the Non-Drive cup**

3 Carefully bracing the tool and frame, very gently hammer/tap the removal tool to push the Non-Drive Cup out of frame

We recommend using a 1.5" headset cup removal tool (photo) as it has a wide stance

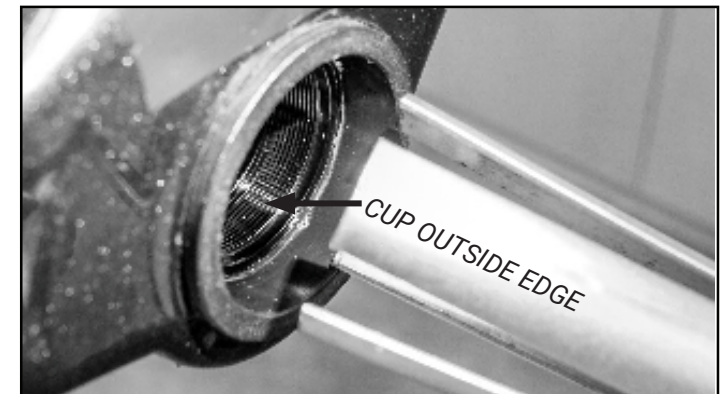

CRANK INSTALLATION

Please see CRANK instructions at www.praxiscycles.com/manuals

BB DUST COVER SETUP

Only 1 cover per side!

**LEFT/NON-DRIVE
28mm I.D.**

(Stepped Cover)

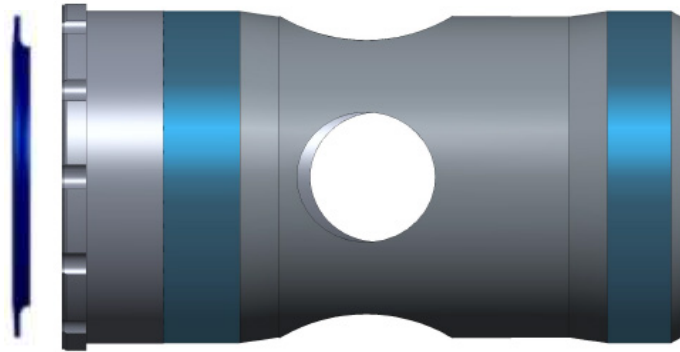

**NEXT PAGE FOR
DUST COVER GUIDE**



**RIGHT/DRIVE
30mm I.D.**

**RIGHT/DRIVE
Wave Washer**

**REFERENCE
FRAME BB SPECS**

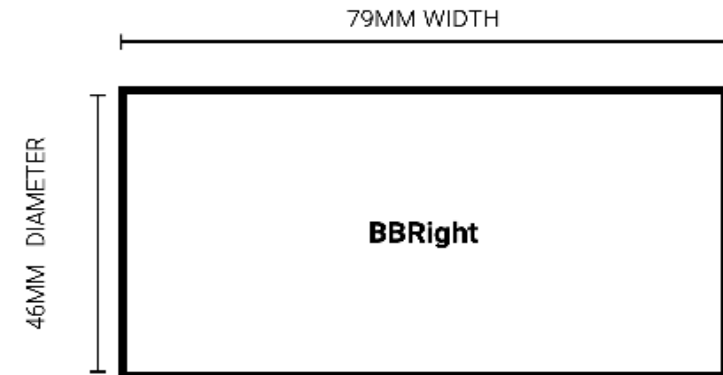

BB DUST COVER GUIDE

ROAD M30	WIDTH	CRANK	LEFT 28MM COVER	LEFT CUP SPACER	RIGHT CUP SPACER	RIGHT 30MM COVER
BSA	68	ROAD DM	2mm	-	-	1mm
		ROAD DM "GR"	2mm	-	-	3mm
		ROAD NON-DM	2mm	-	-	2mm
T47 E.B.	68	ROAD DM	2mm	-	-	1mm
		ROAD DM "GR"	2mm	-	-	3mm
		ROAD NON-DM	2mm	-	-	2mm
T47 I.B.	85.5	ROAD DM	2mm	-	-	1mm
		ROAD DM "GR"	2mm	-	-	3mm
		ROAD NON-DM	2mm	-	-	2mm
BB86	86.5	ROAD DM	2mm	-	-	1mm
		ROAD DM "GR"	2mm	-	-	3mm
		ROAD NON-DM	2mm	-	-	2mm
386EVO	86.5	ROAD DM	2mm	-	-	1mm
		ROAD DM "GR"	2mm	-	-	3mm
		ROAD NON-DM	2mm	-	-	2mm
BB30/PF30	68	ROAD DM	2mm	-	-	1mm
		ROAD DM "GR"	2mm	-	-	3mm
		ROAD NON-DM	2mm	-	-	2mm
* BBRight	79	ROAD DM	2mm	-	-	1mm
		ROAD DM "GR"	2mm	-	-	3mm
		ROAD NON-DM	2mm	-	-	2mm

"DM" = DIRECT MOUNT SPIDER (Removable Spider)

"NON-DM" = NOT DIRECT MOUNT SPIDER (Pressed-On Spider)

"DM GR" = DIRECT MOUNT SPIDER - GRAVEL CRANK (Removeable Spider "GR" crank)