

Light Source: 3 x red CREE XR-LED

Intensity: 84 lumens - High

Beam: 270 degrees visibility

Mounting: QR Bayonet seatpost fitting

Battery: 7.4v Li-Ion 2600/5200mAh compatible

Charge Time: 3hrs/6hrs

Weight: 117g - 250g

Power Levels: 5 functions

Burn Time: 11 - 104 hours



LUMEN OUTPUT



BEAM ANGLE



WEIGHT



POWER LEVELS



BURN TIME

WARRANTY

All Hope Technology lighting systems are covered for one year from original date of purchase against manufacturer defects in material and workmanship. Proof of purchase is required. Product must be returned to Hope Technology to process any warranty claim. This warranty does not cover any damage caused through mis-use or failing to comply by the recommendations given in this manual. This warranty does not affect your statutory rights.

DISPOSAL

When the equipment has reached the end of its life please dispose of the components in accordance with your local waste regulations. Lamps and batteries should be recycled where possible and not disposed of with regular waste.



IMPORTANT INFORMATION

Please take time to read these instructions before use in order to familiarise yourself with the operation of the lighting system. We strongly advise you read the following recommendations in order to prevent injury or damage to the lighting system.

! WARNING

- **This lighting system will withstand harsh wet weather conditions. However, it is not designed to be submersed in water. Please ensure that the light unit and battery pack are removed from the bike before washing - particularly if using a high pressure jet wash.**
- **Class 2 LED. Do not look directly at the beam. Permanent eye damage could result. Consider other road users when mounting the light to avoid dazzling them. Always position the light so that it is pointing slightly downwards so it is not possible to dazzle road users behind (see fig. 1).**
- **Keep this light away from children.**
- **Only connect the rear light to a compatible Hope Vision 7.4 V battery pack, either directly or through the supplied splitter cable. Any attempt to use or charge another battery pack may result in an explosion and/or serious injury.**
- **Do not short-circuit the battery terminals. This causes the battery to overheat and could result in fire or explosion.**
- **The battery charger is designed for indoor use only and should not come into contact with water.**
- **The battery charger contains dangerous voltages and the cover should not be removed. Any attempt to open the charger will invalidate the warranty.**

INSTRUCTION MANUAL

CONTENTS

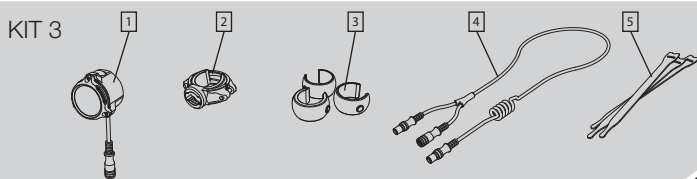
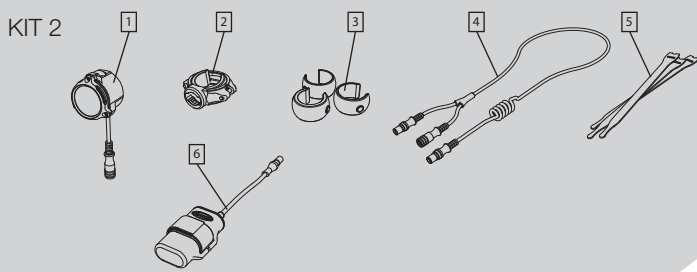
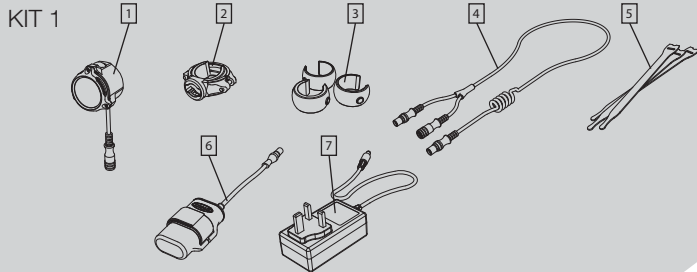

1. Rear LED lamp unit
2. QR bayonet seatpost mount
3. Seatpost spacers (27.2,30.9,31.6)
4. Splitter cable
5. Hook & loop cable straps (x3)
6. Rechargeable battery pack
7. Battery charger

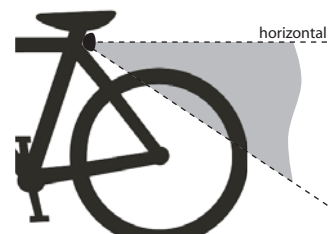
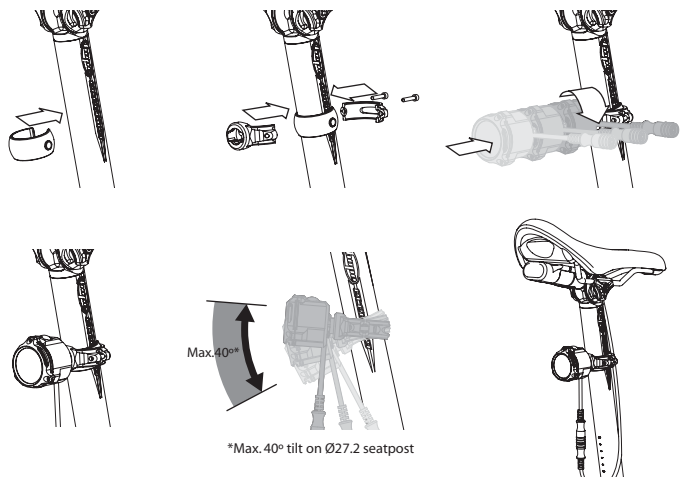

Fig. 1

FITTING INSTRUCTIONS

Fitting the QR seatpost mount and lamp:



Fitting the battery pack and splitter cable:

The District rear lamp can be integrated into a HOPE Vision 2 or Vision 4 front lighting system by using the supplied splitter cable. This gives you the option of mounting the battery pack either at the front of the bike (ie. on the stem) or at the rear of the bike (ie. under the saddle) by reversing the splitter cable. These options are shown below.

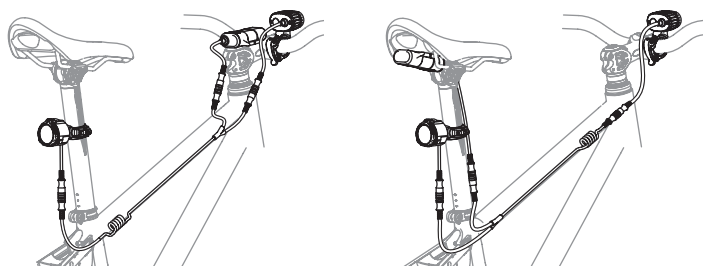

For further information on fitting the District rear lamp see www.hopetech.com

OPERATION OF THE LAMP

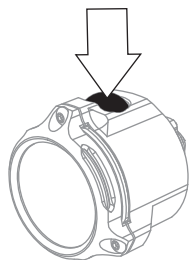

↓	1	Low
↓	2	High
⇓	3	Slow Flash
⇓	4	Fast Flash
⇓	5	Strobe
⇓	6	Off

BATTERY RUN TIMES

POWER LEVEL	BURN TIME (2.6Ah BATTERY)	BURN TIME (5.2Ah BATTERY)
Low	>40 HRS	>80 HRS
High	>10 HRS	>20 HRS
Slow Flash	>20 HRS	>40 HRS
Fast Flash	>20 HRS	>40 HRS
Strobe	>50 HRS	>100 HRS

Note: When used with a stand-alone battery the lamp is designed to maintain a constant level of light output until the battery voltage reaches a low threshold, after which the lamp brightness will begin to dim. It will not shut down suddenly. This is a deliberate safety feature to warn you of a low battery level, so we recommend that once the lamp begins to dim you recharge the battery immediately.

POWER LEVEL	BURN TIME OF 4 LED IN MAX POWER PLUS REAR LAMP (USING 5.2Ah BATTERY AND SPLITTER CABLE)	EFFECT ON THE BURN TIME*	BURN TIME OF 2 LED IN MAX POWER PLUS REAR LAMP (USING 2.6Ah BATTERY AND SPLITTER CABLE)	EFFECT ON THE BURN TIME*
Low	2 HRS 39 MINS	-6 MINS	2 HRS 39 MINS	-6 MINS
High	2 HRS 25 MINS	-20 MINS	2 HRS 25 MINS	-20 MINS
Slow Flash	2 HRS 35 MINS	-10 MINS	2 HRS 35 MINS	-10 MINS
Fast Flash	2 HRS 35 MINS	-10 MINS	2 HRS 35 MINS	-10 MINS
Strobe	2 HRS 41 MINS	-4 MINS	2 HRS 41 MINS	-4 MINS

* The effect on burn times by adding the District rear lamp into the front light system are for indication only and are assuming that the stand-alone burn times for the 4 LED and 2 LED in Max power are 2 hrs 45 mins. Please note that if the District rear lamp is plugged into the front light system it will shut down with the front light when the battery is fully discharged. Therefore it is important to not let the battery fully discharge.

CHARGING THE BATTERY PACK

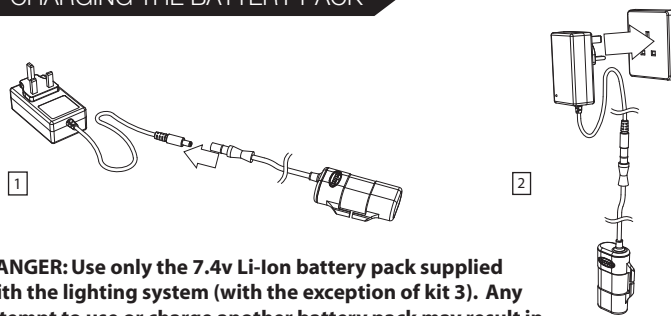

DANGER: Use only the 7.4v Li-Ion battery pack supplied with the lighting system (with the exception of kit 3). Any attempt to use or charge another battery pack may result in explosion and serious injury.

The battery charger is designed for indoor use only and should not come into contact with water.

The mains socket should be easily accessible. In the event of any operational error the plug should be immediately removed from the mains supply. The battery charger contains dangerous voltages and the cover should not be removed. Any attempt to open the charger will invalidate the warranty.

NOTE: The rechargeable battery pack is supplied with a small charge for testing purposes only. Therefore, it is recommended that the battery pack be fully charged before first use.

To correctly charge the battery pack, ensure these steps are followed in order:

- Disconnect from the light unit by pulling apart the two mating dc connectors. Never disconnect the battery from the light unit by pulling the cables. Always use the connector strain relief for grip when disconnecting.
- Before connecting the charger to the mains supply, plug the charger into the battery pack (1).
- Once the battery pack is connected to the charger it may then be plugged into the mains power supply (2). The charger's led indicator will show as orange when a discharged battery is connected, changing to green when fully charged.
- When charging is complete, disconnect from the mains before disconnecting the battery pack from the charger.

Charge Times

A fully discharged 2600mAh battery should take approximately three hours to fully recharge. This time will decrease if the battery was not fully discharged when placed on charge.

STORAGE AND TRANSPORTATION

In order to prevent any malfunction within your Li-Ion battery pack and to preserve the capacity as much as possible, there are a number of procedures which must be considered when storing your battery pack for long periods while not in use (ie. over the summer months).

Storage and transportation:

Never carry the lighting system by the cable. This could result in damage to the electrical connections and will invalidate your warranty. Always disconnect the lamp unit from the battery pack when not in use. When the lamp unit and battery pack are connected there is a small amount of power constantly running through the circuit which could – over a period of time – over discharge the battery pack resulting in loss of battery function and capacity. This will also prevent the lamp unit accidentally switching on and potentially overheating, which could cause permanent damage to the lamp and battery. In extreme cases, overheating could cause fire and/or death.

Storage Temperature:

The battery pack should be stored within the temperature range of -20°C to 25°C in order to preserve cell capacity. Ideally in a cool, dry room such as a cellar or garage.

Over discharging:

As with most battery cells, Li-Ion cells may discharge if they are not used for a long time. In order to prevent over discharging fully charge the battery pack before you store it. Also, charge the battery pack periodically (ie. once every 3-4 weeks) to maintain the cell voltage between 3.4V to 3.8V (a minimum of 50% of the nominal capacity). Over discharging may cause loss of cell performance, or damage battery function.

If these few procedures are followed correctly, you can be sure that when the dark nights creep back in your HOPE VISION battery pack will be fit and raring to go!

MAINTENANCE

There are no serviceable parts inside either the light unit or battery pack. Please do not attempt to disassemble the units, as this will invalidate the warranty. If you find that there is a problem with the functioning of the lighting system please first check that the battery pack is fully charged (see Charging the Battery Pack section). If the light still fails to function please contact Hope Technology.