

***DT SWISS***

***WHEELS***

*SPLINE*

*Technical Manual*

V2016.12

<b>1</b>	<b>General</b>	<b>3</b>
<b>1.1</b>	<b>General Maintenance Information</b> . . . . .	<b>6</b>
<b>2</b>	<b>Safety</b>	<b>7</b>
<b>3</b>	<b>Conversion of the Hub</b>	<b>8</b>
<b>3.1</b>	<b>Overview</b> . . . . .	<b>8</b>
3.1.1	SPLINE® Wheels 2016 . . . . .	8
3.1.2	SPLINE® Wheels 2017 . . . . .	10
<b>3.2</b>	<b>Converting the Hub [Inserted Adapters Version 1]</b> . . . . .	<b>12</b>
<b>3.3</b>	<b>Converting the Hub [Pressed on End Caps]</b> . . . . .	<b>14</b>
<b>3.4</b>	<b>Converting the Hub [Screwed on End Caps]</b> . . . . .	<b>15</b>
<b>3.5</b>	<b>Converting the Hub [Rear Wheel]</b> . . . . .	<b>20</b>
<b>4</b>	<b>Maintenance of the Hub</b>	<b>23</b>
<b>4.1</b>	<b>Hub Technologies</b> . . . . .	<b>23</b>
<b>4.2</b>	<b>Service Intervals</b> . . . . .	<b>24</b>
<b>4.3</b>	<b>Safety</b> . . . . .	<b>24</b>
<b>4.4</b>	<b>Maintenance of the Rear Wheel Hub [Ratchet System]</b> . . . . .	<b>25</b>
<b>4.5</b>	<b>Maintenance of the Rear Wheel Hub [Three Pawl System]</b> . . . . .	<b>31</b>
<b>5</b>	<b>Maintenance of the Wheel</b>	<b>37</b>
<b>5.1</b>	<b>Safety</b> . . . . .	<b>37</b>
<b>5.2</b>	<b>Special Tools</b> . . . . .	<b>38</b>
<b>5.3</b>	<b>Truing the Wheel</b> . . . . .	<b>39</b>
<b>5.4</b>	<b>Changing a Single Spoke [MTB]</b> . . . . .	<b>41</b>
<b>5.5</b>	<b>Rebuilding the Wheel [MTB]</b> . . . . .	<b>47</b>
<b>5.6</b>	<b>Changing a Single Spoke [ROAD]</b> . . . . .	<b>51</b>
5.6.1	Loosening the Spoke . . . . .	51
5.6.2	Changing a Single Spoke on the Front Wheel [Slotted Hub] . . . . .	53
5.6.3	Removing a Single Spoke on the Front Wheel [Non-Slotted Hub] . . . . .	55
5.6.4	Changing a Single Spoke on the Rear Wheel . . . . .	57
<b>5.7</b>	<b>Rebuilding the Wheel [ROAD]</b> . . . . .	<b>59</b>
5.7.1	Putting on the Spokes on the Front Wheel . . . . .	59
5.7.2	Putting on the Spokes on the Rear Wheel . . . . .	60
5.7.3	Connecting the «Spoke Tree» to the Rim . . . . .	61

<b>6</b>	<b>Technical Data</b>	<b>63</b>
<b>6.1</b>	<b>Spoke Tension</b> .....	<b>63</b>
<b>6.2</b>	<b>Tolerances</b> .....	<b>63</b>

---

# 1 General

## Validity

This manual describes the component specified on the front page and the footer. Deviations are possible and all items are subject to technical changes.

## Safety

The safety instructions are classified as follows:



### DANGER

...indicates a hazardous situation that, if not avoided, will result in death or serious injury.



### CAUTION

...indicates a hazardous situation that, if not avoided, could result in a minor or moderate injury.

### NOTICE

...indicates information considered important, but not hazard-related.



...characterizes further information, or information which supplement the respective steps.

## Target Group

This manual is intended for end users and dealers.

It offers the possibility for experienced users to carry out small maintenance works on their own. If there are any doubts concerning the own skills, a DT Swiss service center should be contacted.

Warranty will expire if works are not done properly.

## Layout

The cover page and the footing provide information about the type of product and manual as well as the version of the manual.

The backside provides a list of the DT Swiss service centers. A list of all DT Swiss service centers can be found at [www.dtswiss.com](http://www.dtswiss.com).

This manual is intended for being printed as an A5 booklet. Only print this manual if electronic usage is not possible.

## DT Swiss Manual Concept

The DT Swiss manuals are split into the following types of manuals:

- **User Manual**  
Information for the end user on how to install and use the component.
- **Technical Manual**  
Detailed information for the end user and the dealer on how to maintain the component, spare parts and technical data.

## How to Use this Manual

The steps described in this manual must be carried out in the order they are shown. If steps are ignored or executed in a wrong order, the function of the component cannot be guaranteed.

Instructions begin with the table «Preparatory Steps» and end with the table «Closing Steps». The instructions in these tables must be carried out.

Moving parts, threads, O-rings and sealings must be greased before assembling.

## Cross References

In order to simplify the use of this manual, some text is edited as hypertext. Whenever the text is formatted blue and underlined, it is a reference to a chapter. If the text is formatted black and underlined, it is a reference to a figure. After clicking you will be automatically redirected to the target of the reference.

Example: Click here: [chap. 1, page 3](#) to jump to the beginning of this chapter.

## Warranty (Europe)

In addition to the general guarantee required by law, DT Swiss AG based in Biel/Switzerland, provides a guarantee for 24 months from the date of purchase. DT Swiss AG shall reject any liability for both indirect damage caused by accidents and consequential damage.

Any contradictory or extended national rights of the purchaser are not affected by this warranty. Place of performance and jurisdiction is Biel/Switzerland. Swiss law shall apply.

Submit any warranty claims to your retailer or a DT Swiss service center. Any defects recognized by DT Swiss AG as a warranty claim will be repaired or replaced by a DT Swiss service center.

Warranty and guarantee claims can only be made by the original purchaser with a valid sales receipt.

There shall be no claim under the guarantee for:

- Normal wear and tear caused by use of the components
- Incorrect assembly
- Incorrect or nonexistent maintenance
- Incorrectly completed repairs
- Use of unsuitable products
- Modification of components
- Incorrect use or misuse
- Carelessness
- Leasing, commercial use or use in competitions
- Damage caused by accidents
- Delivery and transport damage
- Modification, defacing or removal of the serial number

## Limited Equipment Warranty USA

DT Swiss LTD makes every effort to assure that its product meets high quality and durability standards and warrants to the original retail consumer/purchaser of our product that each product is free from defects in materials and workmanship as follows:

2 YEAR LIMITED WARRANTY ON THIS DT SWISS PRODUCT. This warranty does not apply to defects due directly or indirectly to misuse, abuse, negligence or accidents, repairs or alterations outside our facilities or to a lack of maintenance.

DT SWISS LTD LIMITS ALL IMPLIED WARRANTIES TO THE PERIOD OF TWO YEARS FROM THE DATE OF INITIAL PURCHASE AT RETAIL. EXCEPT AS STATED HEREIN, ANY IMPLIED WARRANTIES OF MERCHANTABILITY AND FITNESS ARE EXCLUDED. SOME STATES MAY NOT ALLOW LIMITATIONS ON HOW LONG THE IMPLIED WARRANTY LASTS, SO THE ABOVE LIMITATION MAY NOT APPLY TO YOU. DT SWISS LTD SHALL IN NO EVENT BE LIABLE FOR DEATH, INJURIES TO PEOPLE OR PROPERTY OR FOR INCIDENTAL, CONTINGENT, SPECIAL OR CONSEQUENTIAL DAMAGES ARISING FROM THE USE OF OUR PRODUCTS. SOME STATES MAY NOT ALLOW THE EXCLUSION OR LIMITATION OF INCIDENTAL OR CONSEQUENTIAL DAMAGES, SO THE ABOVE LIMITATION OR EXCLUSION MAY NOT APPLY TO YOU.

To take advantage of this warranty, the product or part must be returned for examination, postage prepaid, to the dealer where you bought the product or to a DT Swiss service center. Proof of purchase date and an explanation of the complaint must accompany the product. If our inspection discloses a defect, DT Swiss will either repair or replace the product or refund the purchase price, if we cannot readily and quickly provide a repair or replacement. DT Swiss will return repaired product or replacement at DT Swiss expense, but if it is determined there is no defect, or that the defect resulted from causes not within the scope of this warranty, then the user must bear the cost of shipping. This warranty gives you specific legal rights, and you may also have other rights which vary from state to state. Legal venue and place of performance is Biel (Switzerland). Swiss law shall apply. Subject to technical changes. Please keep the user manual and warranty for future use.

## 1.1 General Maintenance Information

### Cleaning

For an optimal result of the maintenance works, every component that will be disassembled must be cleaned. Only cleaners which do not damage the components may be used. Especially the cleaning of O-rings and sealings requires mild cleaners. Always consider the instructions of the respective cleaner.

DT Swiss recommends the following cleaners:

- Motorex Rex
- Motorex Swissclean
- Motorex OPAL 2400, OPAL 3000, OPAL 5000

Use soap water or similar mild cleaners for external cleaning.

### Tools

If special materials like grease or oil are needed, they will be specified in the table «Required Material» at the beginning of a chapter. The symbol «✂» refers to the table «Required Material» in the respective steps.

### Environmental Protection

Whenever possible, waste has to be avoided. Waste, especially carbon, lubricants, cleaners and any other fluids must be disposed in an environmentally compatible manner.

Only print this manual if electronic usage is not possible.

### Disclaimer

The operations described in this manual should only be performed by experts. The user is liable for any damage or consequential damage caused by wrong maintained or wrong installed components. If you have doubts, please contact a DT Swiss service center.

## 2 Safety



### DANGER

**Incorrect handling, installation, maintenance or servicing can lead to accidents causing severe injuries or death!**

- Compliance with the following provisions is a prerequisite for accident-free use and faultless functioning.
- Assembly and maintenance of the component requires a basic knowledge of handling bicycle components. If in any doubt, consult your retailer.
- Components should only be used in accordance with their intended use, otherwise the user shall assume full responsibility.
- The component must be compatible with all parts of the bicycle.
- Only use original spare parts.
- The components must not be changed or modified.
- The component must not be used if it is damaged or there are any signs of damage. If in any doubt, consult a DT Swiss service center.



### DANGER

**Risk of death caused by incorrectly assembled or faulty wheels and hubs!**

- Check that the wheel is connected correctly before each ride.
- Before every use, check the function of the rear wheel hub. Make sure that the freewheel and engagement connection function impeccably. Should there be any malfunction, the rear wheel hub must not be used.
- Check the wheel for damage before and after each ride.
- Regularly check the spoke tension, rotation and wear of the wheel.



### 3 Conversion of the Hub

The hubs can be converted to the following axle version:

#### 3.1 Overview

##### 3.1.1 SPLINE® Wheels 2016

##### SPLINE® ROAD 2016

	Front Wheel Option						Link	Rear Wheel Option						Link
	5/100 mm QR	9/100 mm Thru Bolt	12/100 mm RWS road	15/100 mm Thru Axle	100 mm Bolt On	5/130 mm QR		5/135 mm QR	10/135 mm Thru Bolt	12/135 mm Thru Axle	12/142 mm Thru Axle	120 mm Bolt On		
RC 28	●							●						
RC 28 db	◐	◐	◐	●		<a href="#">chap.3.5, p.20</a>			◐	◐	○	●		
RC 38	●							●						
RC 38 db	◐	◐	◐	●		<a href="#">chap.3.5, p.20</a>			◐	◐	○	●		
RC 55	●							●						
RC 55 Track					●								●	
RC 46	●							●						<a href="#">chap.3.5, p.20</a>
R 23	●							●						
R 23 db	◐	◐	◐	●		<a href="#">chap.3.5, p.20</a>			◐	◐	○	●		
R 24	●							●						
R 24 db	◐	◐	◐	●		<a href="#">chap.3.5, p.20</a>			◐	◐	○	●		
R 32	●							●						
R 32 db	◐	◐	◐	●		<a href="#">chap.3.5, p.20</a>			◐	◐	○	●		

● Standard    ○ Option    ◐ Convertible with included accessories

SPLINE® MTB 2016

	Front Wheel Option					Link	Rear Wheel Option			Link
	5/100 mm QR	15/100 mm Thru Axle	15/110 mm Thru Axle PS	15/110 mm Thru Axle Boost	20/110 mm Thru Axle		5/135 mm QR	12/142 mm Thru Axle	12/148 mm Thru Axle Boost	
XRC 1200	○	●	● *	● *		<a href="#">chap.3.2, p.12</a>	○	●	● *	<a href="#">chap.3.5, p.20</a>
XR 1501	○	●	● *	● *		<a href="#">chap.3.2, p.12</a>	○	●	● *	
X 1700	◐	●	● *	● *		<a href="#">chap.3.3, p.14</a>	◐	●	● *	
X 1900	◐	●		● *		<a href="#">chap.3.3, p.14</a>	◐	●	● *	
XMC 1200	○	●	● *	● *		<a href="#">chap.3.2, p.12</a>	○	●	● *	
XM 1501	○	●	● *	● *		<a href="#">chap.3.2, p.12</a>	○	●	● *	
M 1700	○	●	● *	● *		<a href="#">chap.3.3, p.14</a>	◐	●	● *	
M 1900	◐	●		● *		<a href="#">chap.3.3, p.14</a>	◐	●	● *	
EX 1501	○	●		● *	●	<a href="#">chap.3.2, p.12</a>	○	●	● *	
E 1700	○	●		● *	● *	<a href="#">chap.3.3, p.14</a>	◐	●	● *	
E 1900	○	●		● *	● *	<a href="#">chap.3.3, p.14</a>	◐	●	● *	

● Standard    ○ Option    ◐ Convertible with included accessories    \* Not convertible

### 3.1.2 SPLINE® Wheels 2017

#### SPLINE® ROAD 2017

	Front Wheel Option							Link	Rear Wheel Option							Link
	5/100 mm QR	9/100 mm Thru Bolt	12/100 mm RWS road	15/100 mm Thru Axle	100 mm Bolt On	5/130 mm QR	5/135 mm QR		10/135 mm Thru Bolt	12/135 mm Thru Axle	12/142 mm Thru Axle	120 mm Bolt On				
RC 28 Mon Chasseral	●							●								
RC 38 Mon Chasseral	●							●								
RC 28	●							●								
RC 28 db	◐	◐	◐	●			<a href="#">chap.3.5, p.20</a>		◐	◐	○	●				
RC 38	●							●								
RC 38 db	◐	◐	◐	●			<a href="#">chap.3.5, p.20</a>		◐	◐	○	●				<a href="#">chap.3.5, p.20</a>
RC 55	●							●								
R 23	●							●								
R 23 db	◐	◐	◐	●			<a href="#">chap.3.5, p.20</a>		◐	◐	○	●				
R 24	●							●								
R 24 db	◐	◐	◐	●			<a href="#">chap.3.5, p.20</a>		◐	◐	○	●				
R 32	●							●								
R 32 db	◐	◐	◐	●			<a href="#">chap.3.5, p.20</a>		◐	◐	○	●				

- Standard
- Option
- ◐ Convertible with included accessories

**SPLINE® MTB 2017**

	Front Wheel Option					Link	Rear Wheel Option			Link
	5/100 mm QR	15/100 mm Thru Axle	15/110 mm Thru Axle PS	15/110 mm Thru Axle Boost	20/110 mm Thru Axle		5/135 mm QR	12/142 mm Thru Axle	12/148 mm Thru Axle Boost	
XRC 1200	○	●	● *	● *		<a href="#">chap.3.2, p.12</a>	○	●	● *	<a href="#">chap.3.5, p.20</a>
XMC 1200	○	●	● *	● *			○	●	● *	
XR 1501	○	●	● *	● *			○	●	● *	
XM 1501 22,5 mm	○	●	● *	● *			○	●	● *	
XM 1501 25, 30, 35, 40 mm	○	●		● *			○	●	● *	
EX 1501 25 mm	○	●		● *	●		○	●	● *	
EX 1501 30 mm	○	●		● *			○	●	● *	
X 1700	◐	●	● *	● *		<a href="#">chap.3.3, p.14</a>	◐	●	● *	
M 1700 22,5 mm	◐	●	● *	● *			◐	●	● *	
M 1700 30 mm	◐	●		● *			◐	●	● *	
E 1700	○	●		● *	● *		◐	●	● *	
X 1900	◐	●		● *			◐	●	● *	
M 1900	◐	●		● *			◐	●	● *	
E 1900	○	●		● *	● *		◐	●	● *	

● Standard    ○ Option    ◐ Convertible with included accessories    \* Not convertible

### 3.2 Converting the Hub [Inserted Adapters Version 1]

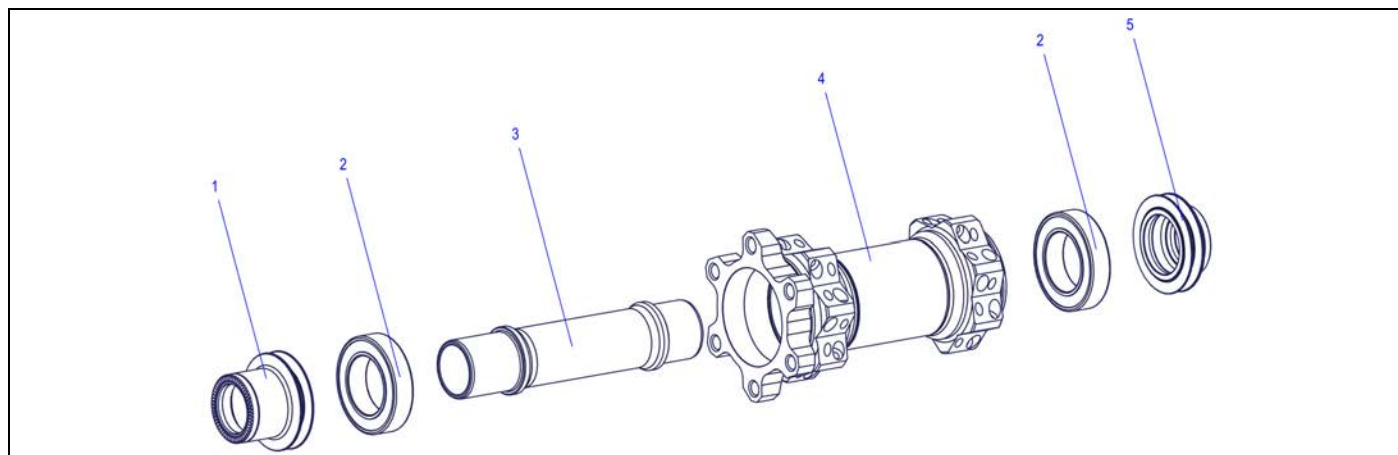

Figure 3-1: Overview: front wheel with inserted adapters (version 1)

- |                |             |                 |
|----------------|-------------|-----------------|
| 1 adapter left | 3 axle      | 5 adapter right |
| 2 ball bearing | 4 hub shell |                 |

Preparatory Steps		Link
not required		
Required Material	Specification	Amount
multi purpose grease		as required

#### NOTICE

##### Risk of damaging the adapters!

To avoid damages, only use grind clamping jaws, aluminium clamping jaws or special tools to clamp the adapters.

#### Removing the Adapters

1. Clamp one of the adapters (Abb.3-1/1, 5) into a vice.
2. Pull off the wheel, respectively the hub.
3. Clamp the second adapter into the vice.
4. Pull off the wheel, respectively the hub.



### Cleaning and Greasing the Parts

1. Clean the hub, the bearings and the adapters (see [Cleaning, S.6](#)).
2. Check the bearings.  
If the hub doesn't turn smoothly, change the bearings (see Technical Manual at [www.dtswiss.com](http://www.dtswiss.com)).
3. Grease the bearings ([Abb.3-1/2](#)) and the contact surface of both adapters ([Abb.3-1/1, 5](#)) with multi purpose grease.



### Putting on the Adapters

1. Put both adapters ([Abb.3-1/1, 5](#)) onto the hub by hand.
- Caution: If the adapters have different lengths, the shorter adapter must be put to the drive side.





Closing Steps

not required

[Link](#)

### 3.3 Converting the Hub [Pressed on End Caps]

Preparatory Steps		Link
Clean the hub.		
Required Material	Specification	Amount
DT Swiss multipurpose grease	 HXTXXX00NMG20S	as required
adapter 15 mm/QR	 HRCXXX00N4369S	1



Limited conversion options!

Hubs with pressed on end caps can't be converted to a different axle diameter by changing the end caps. Only the 15 mm version can be converted by inserting a special adapter.

- Grease the adapter with multipurpose grease.



- Slide the adapter into the hub.



Closing Step	Link
not required	

### 3.4 Converting the Hub [Screwed on End Caps]

Preparatory Steps	Link
Remove the brake disc.	see instructions of the manufacturer
Clean the hub.	

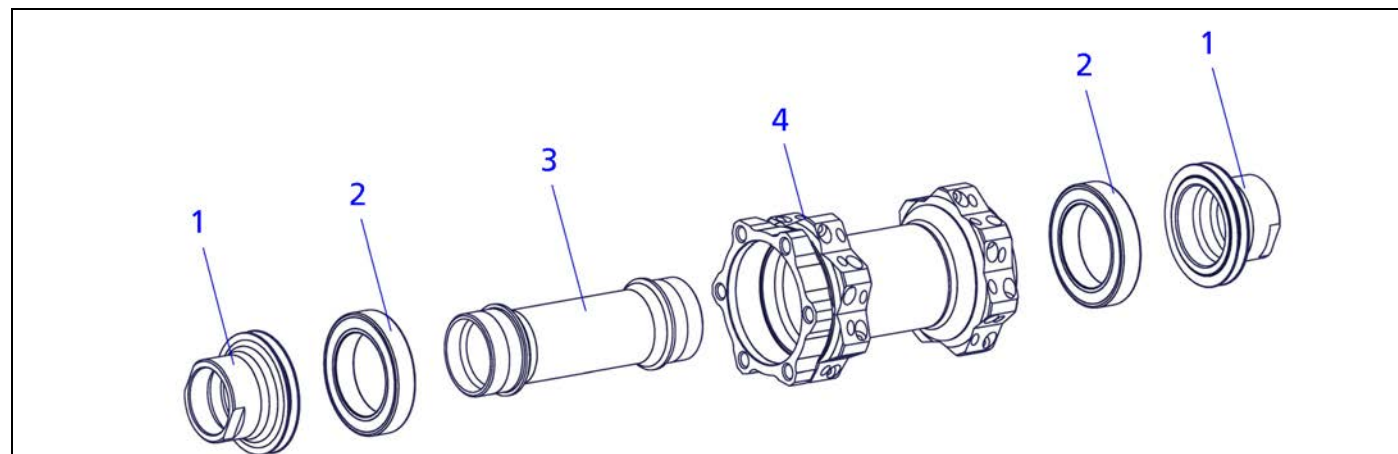





Figure 3-2: 240 Oversize

- 1 end cap
- 2 ball bearing
- 3 axle
- 4 hub shell

Required Material	Specification	Amount
DT Swiss multipurpose grease	 HXTXXX00NMG20S	as required
tool kit set front wheel oversize	HWTXXX00NTKFRS	1 *
	 HXTXXX00N5046S	
	 HXTXXX00N5038S	

\* Only required, if the end caps cannot be dismounted without dismounting the axle.



## Removing the End Caps

1. Loosen the end caps (fig. 3-2/1) using a wrench and remove it from the axle.
  - ⇒ 20 mm, 15 mm und 9 mm end caps: 22 mm open-end wrench
  - ⇒ QR end caps: 5 mm Allen key
2. If the end caps cannot be loosened this way, the axle has to be dismantled (see following).



## Dismounting the Axle



The axle only has to be dismantled, if the end caps cannot be dismantled like shown in the previous section.

1. Slide the disassembly tool onto the axle (fig. 3-2/3).



2. Tap the bearing (fig. 3-2/2) and the axle out of the hub shell using the disassembly tool and a hammer.



3. Clamp the axle with the special strap into the vise.

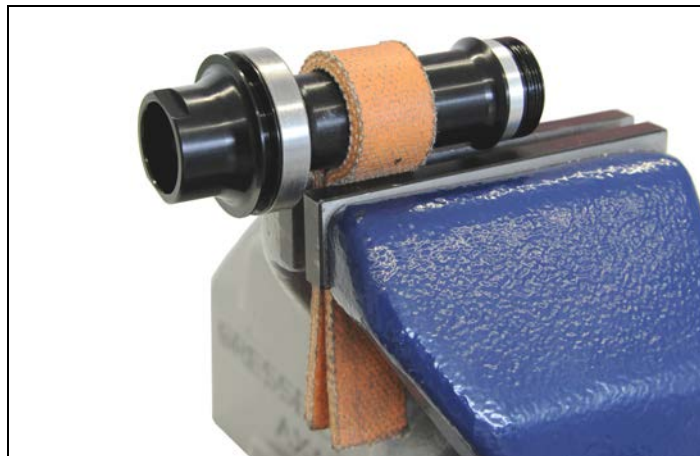

4. Unscrew the end cap and remove it.

- ⇒ 20 mm, 15 mm und 9 mm end caps: 22 mm open-end wrench
- ⇒ QR end caps: 5 mm Allen key



5. Remove the bearing from the axle.



### Assembling Bearings and Axle

1. Slightly grease the seating of the bearings and the inner surface of the hub shell using multipurpose grease.

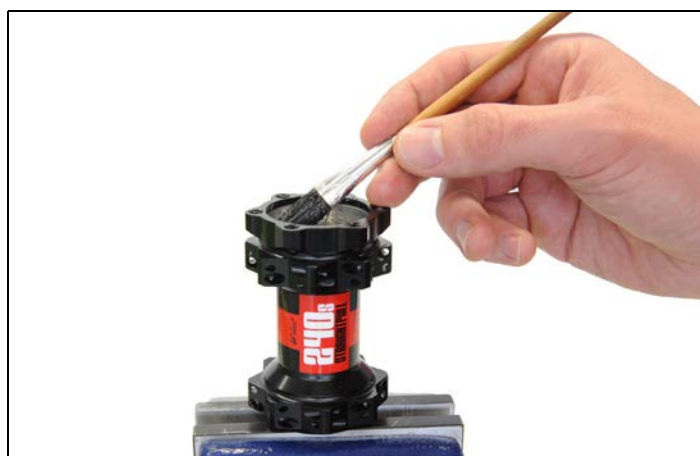

2. Put the axle (fig. 3-2/3) onto the mounting tool.
3. Put the non disc side of the hub shell onto the tool and the axle.
  
4. Slightly grease the bearing (fig. 3-2/2) and put it onto the disc side with the colored side facing outwards.
  
5. Put the dismantling tool onto the axle.
6. Put the mounting tool onto the bearing.
  - ⇒ The dismantling tool centers the mounting tool on the axle.
  
7. Tap the bearing into the hub shell with slight hammer strokes.
  - ⇒ The lower mounting tool must lay on an even surface.
8. Remove the tool from the hub.



9. Check the bearing.
  - ⇒ The hub must turn smoothly.
  - ⇒ The hub must not have axial play.
10. If necessary tap in the bearing on the non disc side or loosen the bearing.
11. Repeat previous steps until the hub is turning smoothly.

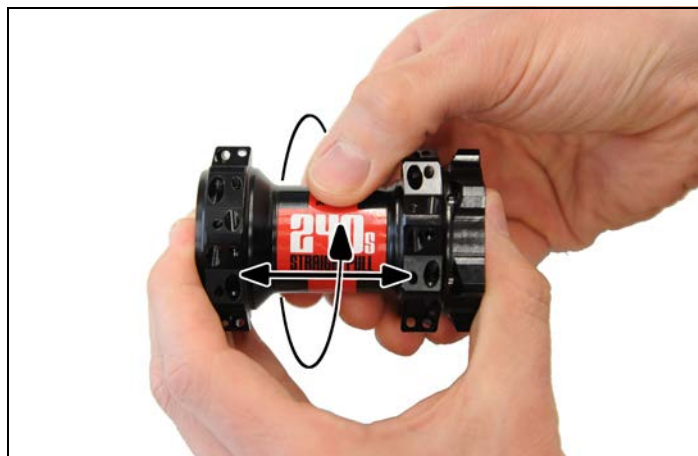

### Putting on the End Caps

1. Grease the bearings and the inner surface of both end caps (fig. 3-2/1).
2. Screw on both end caps (fig. 3-2/1) by hand.



3. Tighten the end cap (fig. 3-2/1) with 15 Nm using a wrench.
  - ⇒ 20 mm, 15 mm und 9 mm end caps: 22 mm open-end wrench
  - ⇒ QR end caps: 5 mm Allen key



### Closing Steps

Mount the brake disc.

Link

see instructions of the manufacturer

### 3.5 Converting the Hub [Rear Wheel]

Preparatory Steps		Link
Rear wheel: Remove the cassette if necessary.		see instructions of the manufacturer
Remove the brake disc.		
Clean the hub.		
Required Material	Specification	Amount
universal grease		as required

#### NOTICE

##### Risk of damaging the end caps!

To avoid damages, only use grind clamping jaws, aluminum clamping jaws or special tools to clamp the end caps.



For simplification, the conversion of the hubs is only shown with a rear wheel QR hub. The following actions are valid for all hubs with inserted end caps.

#### Removing the End Caps

1. Clamp the left end cap into a vise using an axle holder.
2. Pull the hub or the wheel upwards.
3. Clamp the right end cap into a vise using an axle holder.
4. Pull the hub or the wheel upwards.



## Cleaning and Greasing the End Caps

1. Clean both end caps and the accessible parts of the hub with a dry cloth.



2. Grease the bearing and the contact surface of the end caps.



## Putting on the End Caps

1. Put the left and the right end cap onto the hub. Caution: If the end caps have different lengths, the shorter end cap must be put to the drive side.



2. Push in the end caps by hand.

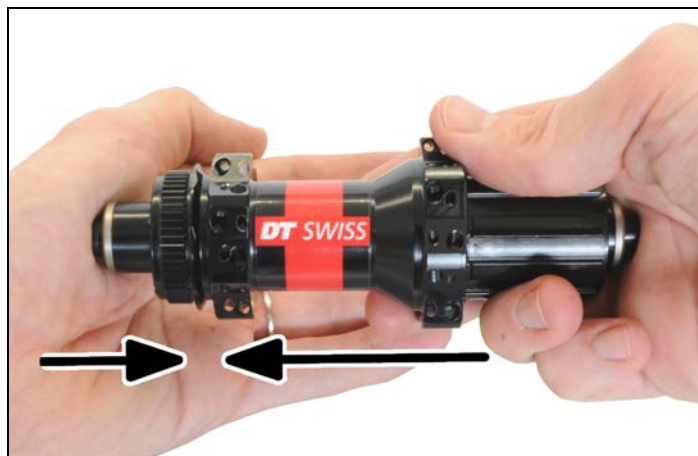

Closing Steps

Rear wheel: Mount the cassette if necessary.

Mount the brake disc.

Link

see instructions of the manufacturer

## 4 Maintenance of the Hub

This chapter describes a small hub service. It includes:

- Rotor: Dismounting, cleaning, greasing and re-mounting
- Freewheel system: Cleaning and greasing

The description of a big hub service can be found in the Technical Manual of the required hub at [www.dtswiss.com](http://www.dtswiss.com).

### 4.1 Hub Technologies

The following table provides an overview of all hub technologies which are part of DT Swiss SPLINE wheels. The link in the header directly forwards you to the required chapter.

#### SPLINE® ROAD

	Ratchet System ( <a href="#">chap. 4.4, page 25</a> )	Three Pawl System ( <a href="#">chap. 4.5, page 31</a> )
RC 28	•	
RC 28 db	•	
RC 38	•	
RC 38 db	•	
RC 46	•	
RC 55	•	
R 23		•
R 23 db		•
R 24		•
R 24 db		•

#### SPLINE® MTB

	Ratchet System ( <a href="#">chap. 4.4, page 25</a> )	Three Pawl System ( <a href="#">chap. 4.5, page 31</a> )
XRC 1250	•	
XR 1501	•	
X 1700	•	
X 1900		•
XM 1501	•	
M 1700	•	
M 1900		•
EX 1501	•	
EX 1750	•	
E 1700	•	
E 1900		•



## 4.2 Service Intervals

The following periodic maintenance and service works are recommended by DT Swiss:

Action	Interval
Small service (see following) <ul style="list-style-type: none"> <li>• normal operating conditions</li> <li>• extreme operating conditions (frequent rides in rain, mud, snow):</li> </ul>	6 months as required
Big service (see Technical Manual at <a href="http://www.dtswiss.com">www.dtswiss.com</a> ) <ul style="list-style-type: none"> <li>• normal operating conditions:</li> <li>• extreme operating conditions (frequent rides in rain, mud, snow):</li> </ul>	12 months as required
Check the hub for damages.	before and after each ride
Cleaning with a soft sponge and an appropriate cleaner (see <a href="#">Cleaning, p.6</a> ). Do not use high pressure cleaners or aggressive cleaners.	after each ride

## 4.3 Safety



### DANGER

#### **Danger to life due to incorrect maintenance or wrong spare parts!**

Wrong maintenance, wrong assembly or wrong spare parts can lead to unpredictable errors.

- Maintenance must only be done by professionals.
- Only use original spare parts or spare parts released by DT Swiss.
- In case of any doubts, contact a DT Swiss service center.

#### 4.4 Maintenance of the Rear Wheel Hub [Ratchet System]

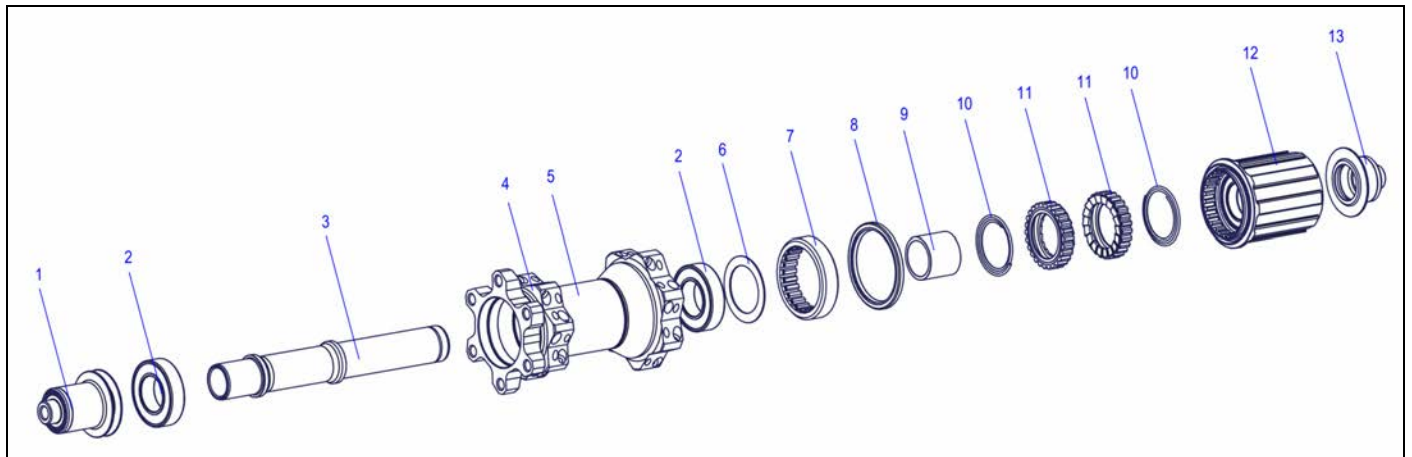

Figure 4-1: Overview: Ratchet System

- |                |                          |                  |
|----------------|--------------------------|------------------|
| 1 end cap left | 6 shim ring              | 11 star ratchet  |
| 2 ball bearing | 7 ring nut               | 12 rotor         |
| 3 axle         | 8 seal hub shell / rotor | 13 end cap right |
| 4 hub shell    | 9 spacer                 |                  |
| 5 sticker      | 10 spring                |                  |

##### Preparatory Steps



##### Link

Remove the cassette.

see instructions of the manufacturer

Remove the brake disc.

Clean the hub.

Required Material	Specification	Amount
DT Swiss multipurpose grease	 HXTXXX00NMG20S	as required
DT Swiss special grease for ratchet system	 HXTXXX00NSG20S	as required

## NOTICE

### Risk of damaging the end caps!

To avoid damages, only use grind clamping jaws, aluminum clamping jaws or special tools to clamp the end caps.

## Removing End Caps, Rotor and the Ratchet System

1. Clamp the left end cap (fig. 4-1/1) into a vise.
2. Pull off the wheel, respectively the hub.
3. Clamp the left end cap (fig. 4-1/13) into a vise.
4. Pull off the wheel, respectively the hub. Take care that the rotor does not fall off.
5. Pull the rotor (fig. 4-1/12) off the hub.
6. Take the springs (fig. 4-1/10), the star ratchet (fig. 4-1/11) and the spacer (fig. 4-1/9) off the hub.

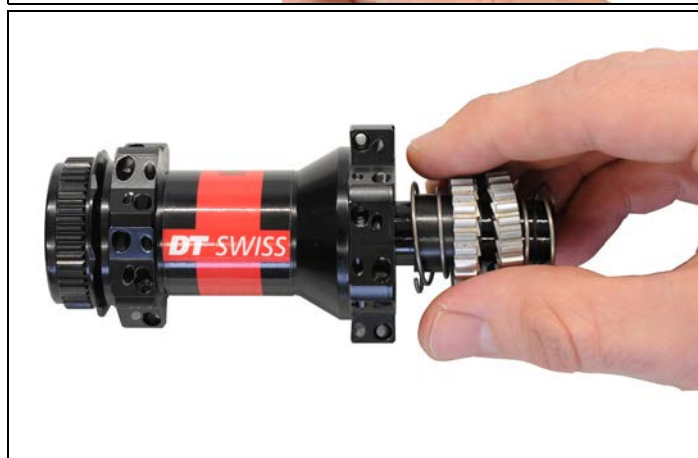

## Cleaning and Checking the Parts

1. Clean all parts of the hub (see [Cleaning, S.6](#)).
2. Check all parts for damages and wear.
3. Check the bearings.  
If the hub doesn't turn smoothly, change the bearings (see Technical Manual at [www.dtswiss.com](http://www.dtswiss.com)).

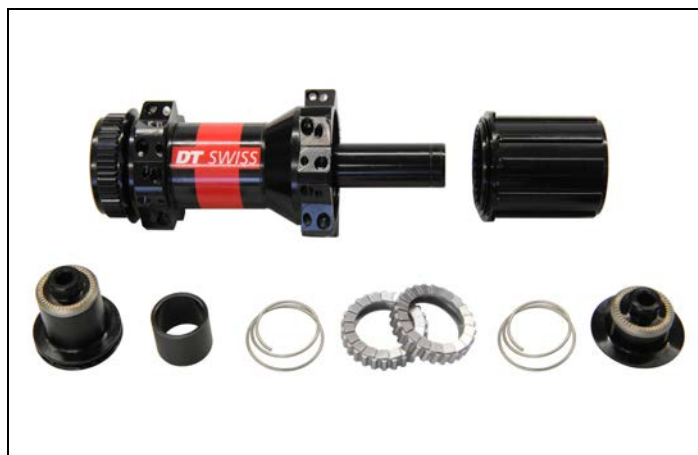

4. Clean the tothing of the rotor and the ring nut.



5. Check the rotor for damages.  
Grooves from the cassette are no damages. These are normal signs of usage.
6. Remove bad notches from the rotor using a file.
7. Clean the rotor. Metal filings must be removed completely.



## Putting on the Ratchet System

1. Clean the outer and the inner toothing of the star ratchets using DT Swiss special grease. For an optimal functionality, a thin layer of grease is sufficient.



2. Grease the toothing of the rotor using DT Swiss special grease.



3. Grease the bearing on the drive side using multi-purpose grease. Caution: There must not get grease onto the toothing of the star nut.



4. Put on the spacer (fig. 4-1/9) and the first spring (fig. 4-1/10). The big diameter of the spring must be placed on the bearing of the hub.



- Put on both star ratchets (fig. 4-1/11) and the second spring (fig. 4-1/10). The small diameter of the spring must be placed on the star ratchet.



### Putting on the Rotor and the End Caps

- Grease the rotor and put it onto the hub.
- Check if the rotor can be turned easily and if the star ratchets are locking.



- Grease both bearings and the contact surface of the end caps (fig. 4-1/1/13).



- Put both end caps (fig. 4-1/1/13) onto the hub.

Note: The shorter end cap must be placed on the drive side.

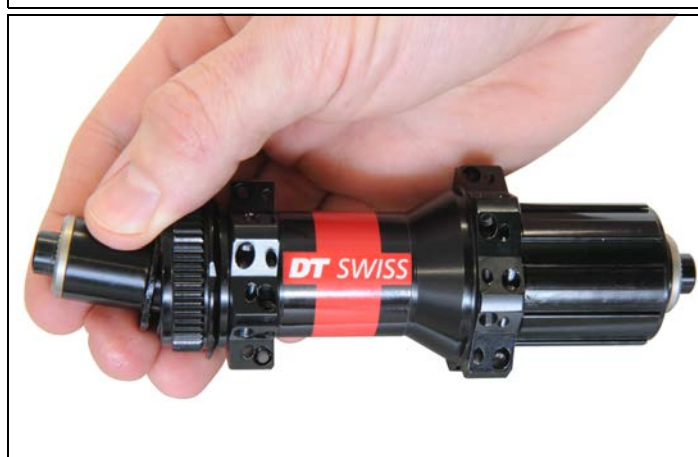

5. Push the end caps in by hand.

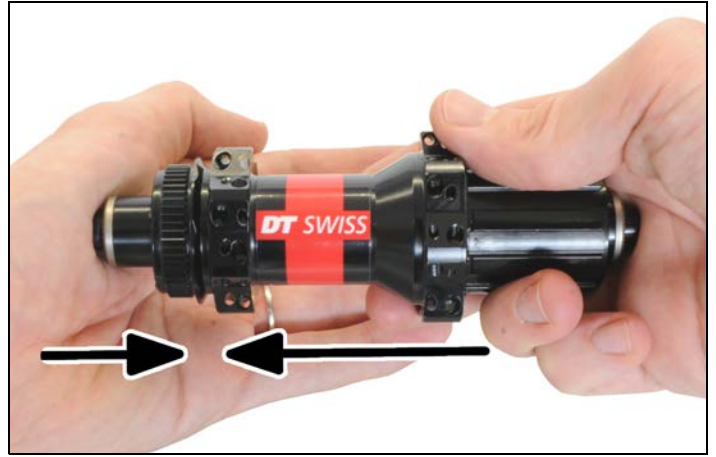

Closing Steps

- Mount the cassette.
- Mount the brake disc.

Link

see instructions of the manufacturer

## 4.5 Maintenance of the Rear Wheel Hub [Three Pawl System]

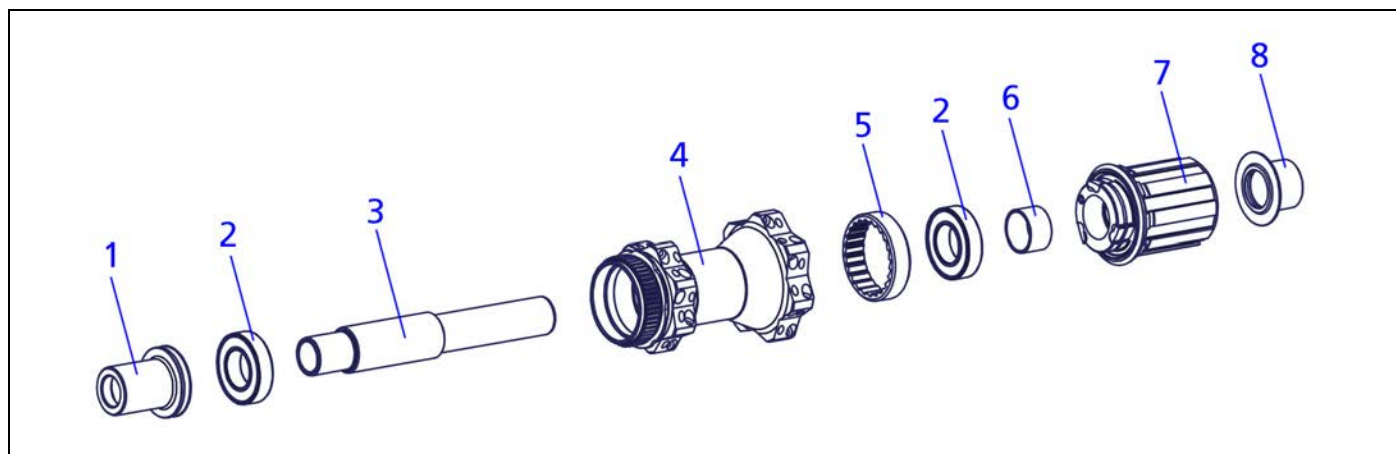

Figure 4-2: Overview Three Pawl System

- |                |             |                 |
|----------------|-------------|-----------------|
| 1 end cap left | 4 hub shell | 7 rotor         |
| 2 ball bearing | 5 ring nut  | 8 end cap right |
| 3 axle         | 6 spacer    |                 |

### Preparatory Steps



### Link

Remove cassette.

see instructions of the manufacturer

Remove the brake disc.

Clean the hub.

Required Material	Specification	Amount
DT Swiss multipurpose grease	 HXTXXX00NMG20S	as required
service kit 3 pawl system	 HWTXXX00NSK3PS includes spring, three pawls, multipurpose grease	as required

## NOTICE

### Risk of damaging the end caps!

To avoid damages, only use grind clamping jaws, aluminum clamping jaws or special tools to clamp the end caps.



### Removing the End Cap, Rotor and Spacer

1. Clamp the right end cap (fig. 4-2/8) into a vise.
2. Pull off the wheel, respectively the hub. Take care that the rotor (fig. 4-2/7) does not fall off.
3. Clamp the left end cap (fig. 4-2/1) into a vise.
4. Pull off the wheel, respectively the hub.



5. Pull the rotor (fig. 4-2/7) off the hub.



6. Pull the spacer (fig. 4-2/6) off the axle.



### Removing Pawls, Spring and Rotor Sealing

1. Remove the spring using a small, flat screwdriver.
2. Remove the pawls.



3. Remove the rotor sealing.
4. Check the sealing. Change a broken sealing.



### Cleaning and Checking the Parts

1. Clean all parts of the hub (see [Cleaning, S.6](#)).
2. Check all parts for wear and damages.
3. Check the bearings.  
If the hub doesn't turn smoothly, change the bearings (see Technical Manual at [www.dtswiss.com](http://www.dtswiss.com)).



4. Check the rotor for damages. Grooves from the cassette are no damages. These are normal signs of usage.
5. Remove bad notches from the rotor using a file.
6. Clean the rotor. Metal filings must be removed completely.



### Mounting the Pawls, the Spring and the Rotor Sealing

1. Mount the rotor sealing.



2. Slightly grease the rotor (fig. 4-2/7) and the rotor sealing.



3. Mount the pawls. Grease the pawls generously. This way, the pawls stuck in the correct position.



- 4. Mount the spring.  
The open end of the spring must be positioned at the pin.



- 5. Slightly grease the pawls with multipurpose grease.



### Mounting the Spacer, the Rotor and the End Caps

- 1. Grease the bearing and the axle.



- 2. Slide the spacer (fig. 4-2/6) onto the axle.



3. Slide the rotor (fig. 4-2/7) onto the hub while performing a rotary motion.
4. Check if the rotor can be turned easily and if the pawls lock.



5. Grease the bearings and the inner surface of both end caps (fig. 4-2/1, 8).



6. Put on both end caps (fig. 4-2/1, 8) and push them in by hand.

Caution: The shorter end cap must be attached on the drive side.



Closing Steps

- Mount the cassette.
- Mount the brake disc.

Link

see instructions of the manufacturer

## 5 Maintenance of the Wheel

This chapter describes activities which are concerning the whole wheel:

- Truing the wheel
- Changing of a single spoke
- Rebuilding the wheel

The following periodic maintenance is recommended by DT Swiss:

Action	Interval
Check spoke tension, run-out and wear of the wheel.	10 hours of use
Check the wheel for damages.	before and after each ride
Clean the wheel with a soft cloth and an appropriate cleaner. Do not use high pressure cleaners and aggressive cleaners!	after each ride
Check the proper fixation of the wheel.	before each ride
Wheels for rim brakes: <ul style="list-style-type: none"> <li>• Remove any contaminations (especially oil and traces of grease) from the brake surfaces.</li> <li>• Check the degree of wear of the brake pads.</li> <li>• Remove any entrenched impurities (grit, swarf, etc.).</li> <li>• Check the degree of wear of the rim brake surfaces. In case of any doubts or viewable wear, contact a skilled professional.</li> </ul>	before each ride

### 5.1 Safety









#### DANGER

**Danger to life due to incorrect maintenance or wrong spare parts!**

Wrong maintenance, wrong assembly or wrong spare parts can lead to unpredictable errors.

- Maintenance must only be done by professionals.
- Only use original spare parts or spare parts released by DT Swiss.
- In case of any doubts, contact a DT Swiss service center.

## 5.2 Special Tools

Required Material	Specification	
spokey square		TTSXXXXR05633S
nipple wrench Torx		TTSXXXXS05630S
nipple wrench hex		TTSXXXXB05632S
aero spoke holder 0.8 - 1.0 mm (DT aerolite®)		TTSXXXXR05641S
aero spoke holder 1.0 - 1.3 mm (DT aero comp®, DT new aero®, DT aero speed®)		TTSXXXXS05644S
tensiometer DT tensio analog		TETTAXXR05500S
axle holder Park Tool AV-1		HXTXXX00N5001S

## 5.3 Truing the Wheel

### Preparatory Steps

Dismount the wheel.

Dismount the tire and if necessary the tube and the rim tape.

### NOTICE

#### Functional impairment / risk of damage due to wrong tools!

Only use the special tools intended for SPLINE® wheels (see [chap. 5.2, page 38](#)).

1. Fix the wheel in the truing stand.
2. Check the radial and axial run out.



### NOTICE

#### Risk of damaging the bladed spokes and the nipples!

- Bladed spokes must be hold with the spoke holder while turning the nipple.
- Whenever possible there should be used the universal spoke holder (see [chap. 5.2, page 38](#)) to avoid damages to the spokes. The spoke holder made out of metal (see [chap. 5.2, page 38](#)) should only be used if the universal spoke holder can't be used due to the high torque.
- There are used different spokes types (see [chap. 6.1, page 63](#)). Ensure that the correct tool is being used.
- To avoid damages to the spoke, slide the spoke holder as far as possible in direction of the rim.
- To avoid damages to the nipples, slide the nipple wrench as far as possible onto the nipple.



3. Slide the nipple wrench onto the nipple.  
To avoid damages to the nipples, slide the nipple wrench as far as possible onto the nipple.



Wheels with bladed spokes:

4. Slide the spoke holder onto the spoke.  
To avoid damages of the spoke, slide the spoke holder as far as possible into the nipple wrench.
5. Align the spoke.
6. True the wheel.



SPLINE® wheels should be distressed minimum four times during the building process. First time at approximately 50% of the maximum spoke tension (see [chap. 6.1, page 63](#)). After finishing truing, the wheel should be distressed once again. There should be no more changes in the settings (spoke tension, radial and axial run out).

After distressing the wheel should be within the limits shown in [chap. 6.2, page 63](#).

7. Check the radial and axial run out again. Repeat last steps if necessary.
8. Check the spoke tension (see [chap. 6.1, page 63](#)) and increase or decrease it.
9. Check the radial and axial run out again. Repeat last steps if necessary.

#### Closing Steps

---

Mount tire and if necessary rim tape and tube.

---

Mount the wheel if necessary.

## 5.4 Changing a Single Spoke [MTB]

### Preparatory Steps

Dismount the wheel.

Dismount the tire and if necessary the tube and the rim tape.

Clean the wheel and check for damages.



If four or more spokes have to be replaced, the whole wheel should be rebuild.

### NOTICE

#### Risk of damaging the bladed spokes and the nipples!

- Bladed spokes must be hold with the spoke holder while turning the nipple.
- Whenever possible there should be used the universal spoke holder (see [chap. 5.2, page 38](#)) to avoid damages to the spokes. The spoke holder made out of metal (see [chap. 5.2, page 38](#)) should only be used if the universal spoke holder can't be used due to the high torque.
- There are used different spokes types (see [chap. 6.1, page 63](#)). Ensure that the correct tool is being used.
- To avoid damages to the spoke, slide the spoke holder as far as possible in direction of the rim.
- To avoid damages to the nipples, slide the nipple wrench as far as possible onto the nipple.

### Removing the Spoke to be Replaced

1. Put the wheel into the truing stand.



The following steps are based on a broken spoke. If the spoke is not broken, but damaged, it can be cut with a wire cutter or something similar.

2. If necessary, cut the spoke:
  - a) Release the spoke using a screw clamp.
  - b) Cut the spoke.
  - c) Take off the screw clamp.



3. Check if there is a washer (PHR washer) on the nipple.
4. Take the spoke with the nipple out of the rim. If there is a PHR washer: Take care that the washer does not fall into the rim profile.



Only for spokes in the inner spoke holes of the hub flange.

5. Fully loosen the spoke (green) opposite the spoke head of the spoke (red) that needs to be replaced.

Caution: The figure shows a wheel with bladed spokes.



Only for spokes in the inner spoke holes of the hub flange.

6. Put the spoke (green) opposite the head of the spoke (red) that needs to be replaced into the middle of the spoke tree.

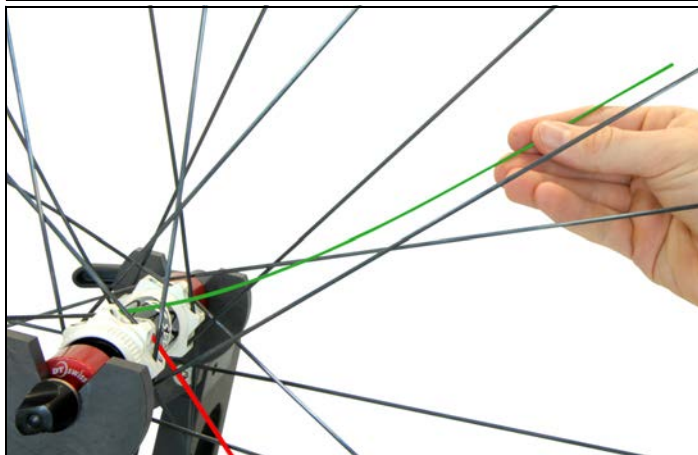

## NOTICE

### Risk of damaging the spokes and the hub!

Take care not to damage the paint of the spoke and the hub while removing the spoke.

Only for spokes in the inner spoke holes of the hub flange.

**7.** Push the green spoke beside and slide out the spoke that needs to be replaced (red).

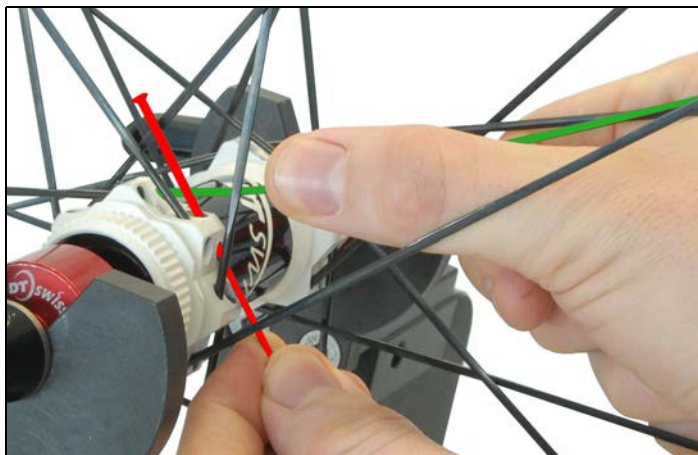

**8.** Remove the spoke.



## Attaching a New Spoke [Conventional SPLINE® Wheels]

For attaching a new spoke on a SPLINE ONE wheel, see [Attaching a New Spoke \[SPLINE ONE\]](#).

1. Slide the new spoke through the spoke hole. Push the opposite spoke beside slightly.



2. Screw on a new nipple.

Caution: The figure shows a wheel with bladed spokes.



3. Tighten the changed and the loosened spoke.

Caution: The figure shows a wheel with bladed spokes.



## Attaching a New Spoke [SPLINE ONE]

For attaching a new spoke on a conventional SPLINE® wheel, see [Attaching a New Spoke \[Conventional SPLINE® Wheels\]](#).

### NOTICE

#### Caution!

SPLINE ONE wheels must only be build with DT Swiss Squorx nipples and special washers (PHR washers).

1. Grease the contact surface of the PHR washer and the Squorx nipple.

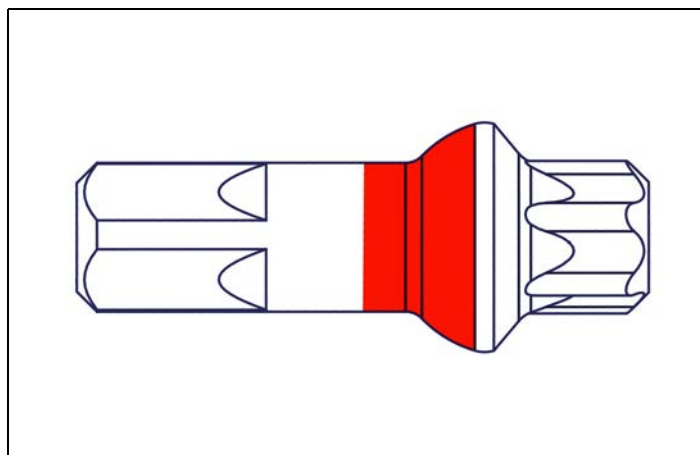

2. Slide the PHR washer onto the nipple. Orientation of the washer, see figure.

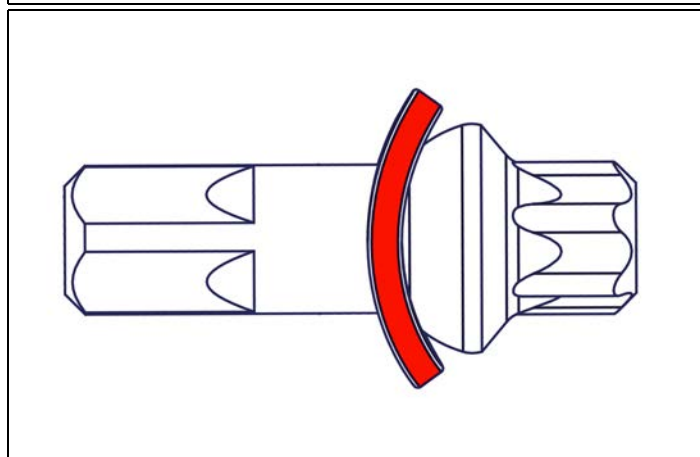

3. Put the spoke through the hub.
4. Screw the Squorx nipple onto the spoke.
5. Check, if the PHR-washer is positioned correctly and fits correctly within the radius of the rim.

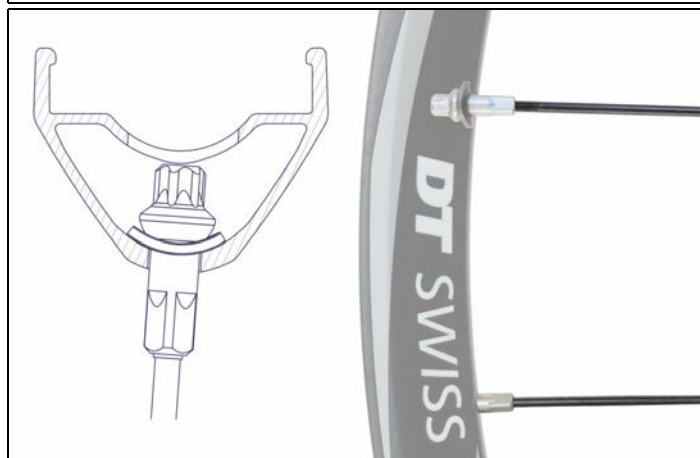

6. Screw the Squorx nipple onto the spoke until the thread disappears.



Closing Steps

Link

True the wheel.

[chap. 5.3, page 39](#)

Mount tire and if necessary rim tape and tube or tubeless system.

Mount the wheel if necessary.

## 5.5 Rebuilding the Wheel [MTB]

### Preparatory Steps

All spokes are available in the correct lengths.

### Putting on the Spokes

General:

The crossing of the spokes must always be like shown in the picture.

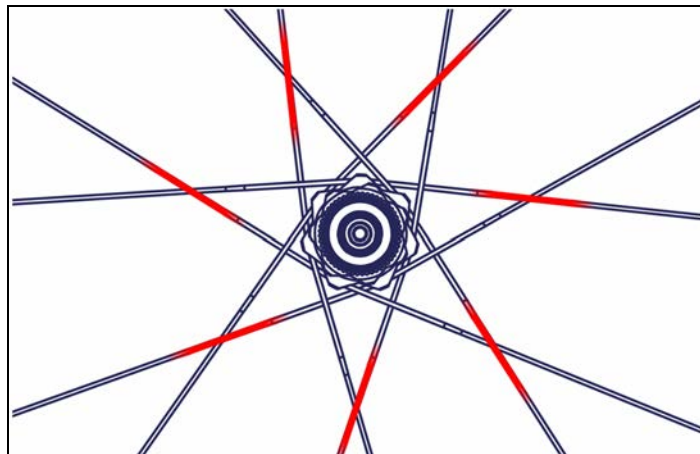

1. Slide all spokes through the spoke holes on the first side of the hub.
  - ⇒ For easier handling, first put the spokes into the inner side of the hub.

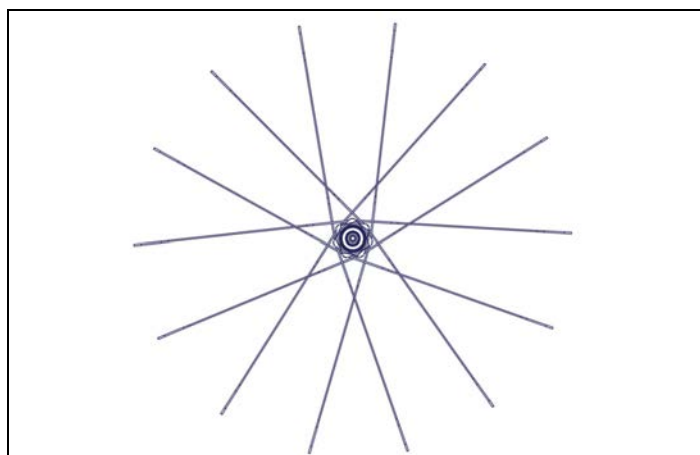

2. Slide all spokes through the spoke holes on the second side of the hub.
  - ⇒ For easier handling, first put the spokes into the inner side of the hub.

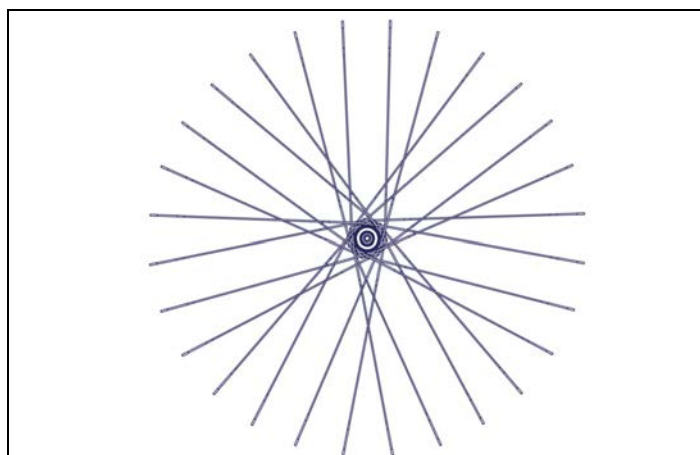



3. Position the «spoke tree» in the way that there is no spoke crossing above the valve hole.
  - ⇒ Check the positioning of the stickers on the hub and on the rim.

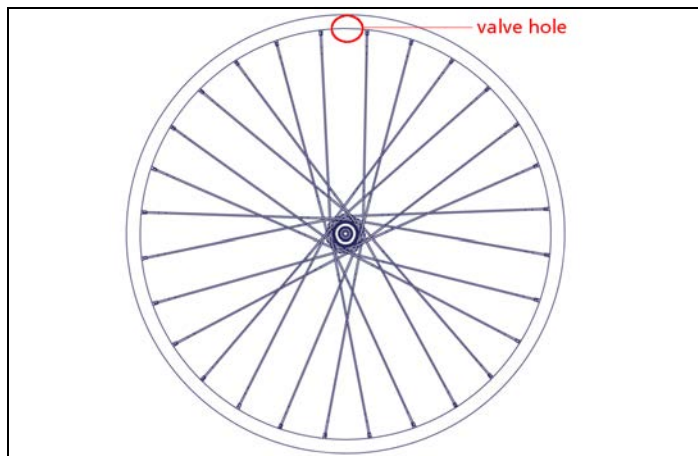

### Putting on the Nipple [Conventional SPLINE® Wheels]

Attaching a nipple on a SPLINE ONE Wheel, see [Putting on the Nipple \[SPLINE ONE Wheels\]](#).

## NOTICE

### Risk of damage to the bladed spokes and the nipples!

- Bladed spokes must be hold with the spoke holder while turning the nipple.
- Whenever possible, use the universal spoke holder (see [chap. 5.2, page 38](#)) to avoid damages to the spokes. The spoke holder made out of metal (see [chap. 5.2, page 38](#)) should only be used if the universal spoke holder can't be used due to the high torque.
- Different spokes types are used (see [chap. 6.1, page 63](#)). Ensure that the correct tool is being used.
- To avoid damages to the spoke, slide the spoke holder as far as possible in direction of the rim.
- To avoid damages to the nipples, slide the nipple wrench as far as possible onto the nipple.

1. Screw the nipple onto the spoke until the thread disappears.
2. Repeat step on all spokes.

Caution: The figure shows a wheel with bladed spokes.



## Putting on the Nipple [SPLINE ONE Wheels]

® Attaching of a nipple on a conventional SPLINE wheel, see [Putting on the Nipple \[Conventional SPLINE® Wheels\]](#).

### NOTICE

#### Caution!

SPLINE ONE wheels must only be build with DT Swiss Squorx nipples and special washers (PHR washers).

1. Grease the contact surface of the PHR washer and the Squorx nipple.

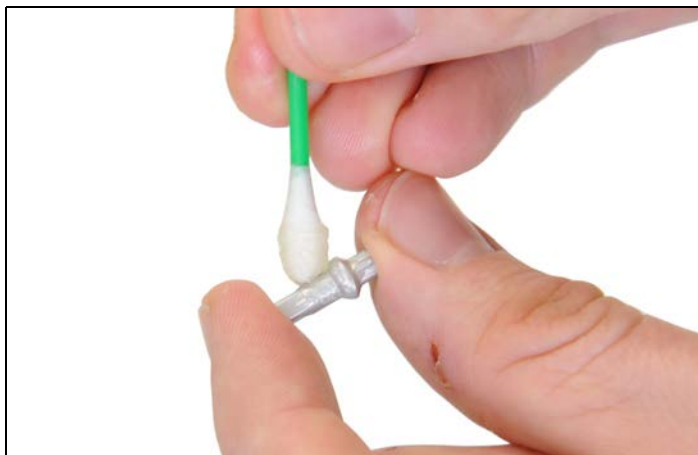

2. Slide the PHR washer onto the nipple.



3. Put the spoke through the hub.
4. Screw the Squorx nipple onto the spoke.
5. Check, if the PHR washer is positioned correctly and fits correctly within the radius of the rim

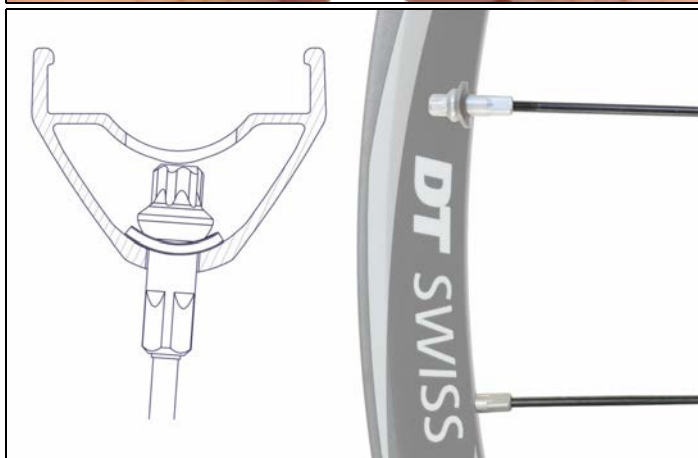

6. Screw the Squorx nipple onto the spoke until the thread disappears.



### Increasing the Spoke Tension

1. Increase the spoke tension (see [chap. 6.1, page 63](#)) by using appropriate tools (see [chap. 5.2, page 38](#)).

Caution: The figure shows a wheel with bladed spokes.



### Closing Steps

True the wheel.

### Link

[chap. 5.3, page 39](#)

## 5.6 Changing a Single Spoke [ROAD]

### NOTICE

#### Risk of damaging the bladed spokes and the nipples!

- Bladed spokes must be hold with the spoke holder while turning the nipple.
- Whenever possible there should be used the universal spoke holder (see [chap. 5.2, page 38](#)) to avoid damages to the spokes. The spoke holder made out of metal (see [chap. 5.2, page 38](#)) should only be used if the universal spoke holder can't be used due to the high torque.
- There are used different spokes types (see [chap. 6.1, page 63](#)). Ensure that the correct tool is being used.
- To avoid damages to the spoke, slide the spoke holder as far as possible in direction of the rim.
- To avoid damages to the nipples, slide the nipple wrench as far as possible onto the nipple.



If four or more spokes have to be replaced, the whole wheel should be rebuild.

### 5.6.1 Loosening the Spoke

#### Preparatory Steps

---

Dismount the wheel.

---

Dismount the tire and if necessary the tube and the rim tape.

---

Clean the wheel and check for damages.



The following steps are based on a broken spoke. If the spoke is not broken, but damaged, it can be cut with a wire cutter or something similar.

1. If necessary, cut the spoke:
  - a) Release the spoke using a screw clamp.
  - b) Cut the spoke.
  - c) Take off the screw clamp.



2. If necessary, loosen the spoke by hand.
  - a) Slide the spoke holder onto the spoke.
  - b) Unscrew the nipple using the nipple wrench. Take care that the nipple does not fall into the rim profile.



Closing Steps

Replace the spoke.

Link

see following

## 5.6.2 Changing a Single Spoke on the Front Wheel [Slotted Hub]

Preparatory Steps	Link
Dismount the wheel.	
Dismount the tire and if necessary the tube and the rim tape.	
Clean the wheel and check for damages.	
Loosen the spoke.	<a href="#">chap. 5.6.1, page 51</a>

**1.** Take off the end cap by hand.



**2.** Slide the spoke with the nipple out of the rim.



**3.** Take the other end of the spoke out of the hub.

**4.** Put on a new spoke.

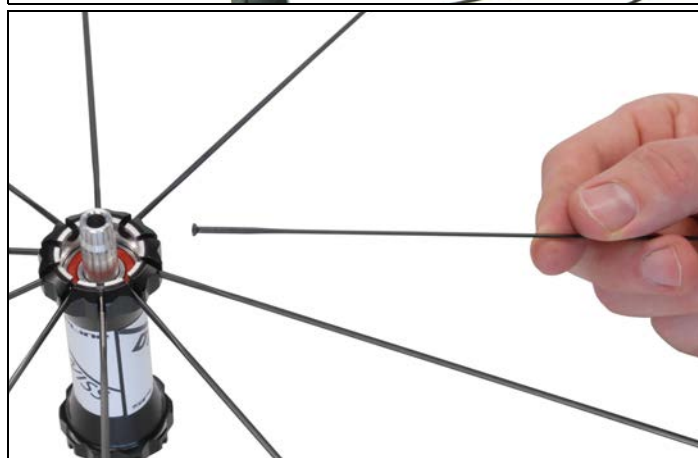

- 5. Screw on a new nipple.
- 6. Tighten the spoke.



- 7. Check the bearing: Clean and grease the bearing if it is badly soiled.
- 8. Put on the end cap.



Closing Steps

Link

True the wheel.

[chap. 5.3, page 39](#)

Mount tire and if necessary rim tape and tube.

Mount the wheel if necessary.

### 5.6.3 Removing a Single Spoke on the Front Wheel [Non-Slotted Hub]

Preparatory Steps	Link
Dismount the wheel.	
Dismount the tire and if necessary the tube and the rim tape.	
Clean the wheel and check for damages.	
Loosen the spoke.	<a href="#">chap. 5.6.1, page 51</a>

1. Remove the end cap.
  - a) Put the axle holder (see [chap. 5.2, page 38](#)) into a vise.
  - b) Clamp the end cap on the side of the spoke which needs to be replaced into the axle holder.
  - c) Pull the wheel upwards using both hands.
  - d) Remove the end cap from the vise.



2. Slide the spoke with the nipple out of the rim.



3. Slide the spoke out of the hub.
4. Slide a new spoke through the hub.





- 5. Screw on a new nipple.
- 6. Tighten the spoke.



- 7. Check the bearing: Clean and grease the bearing if it is badly soiled.
- 8. Put on the end cap.



Closing Steps

- True the wheel.
- Mount tire and if necessary rim tape and tube.
- Mount the wheel if necessary.

Link

[chap. 5.3, page 39](#)

## 5.6.4 Changing a Single Spoke on the Rear Wheel

Preparatory Steps	Link
Dismount the wheel.	
Dismount the tire and if necessary the tube and the rim tape.	
Clean the wheel and check for damages.	
Loosen the spoke.	<a href="#">chap. 5.6.1, page 51</a>

### Removing the Spoke

1. Slide the spoke with the nipple out of the rim.
2. Only for spokes on the inner side of the hub: Pull the spoke over the spoke of the second crossing.
3. Slide the spoke through the hub and remove it.

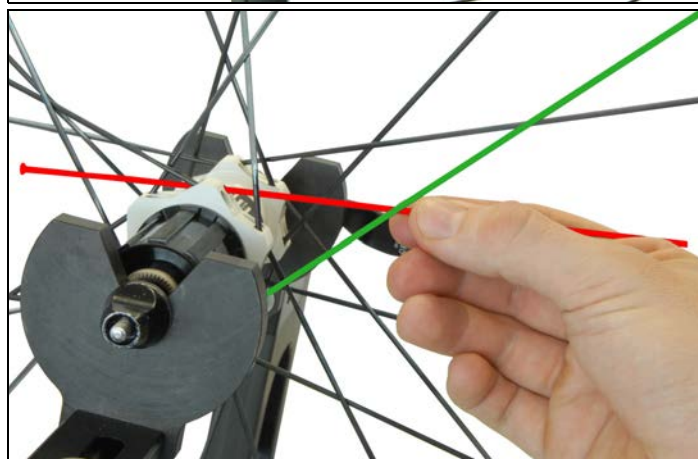

### Attaching a New Spoke

1. Slide a new spoke through the spoke hole of the hub.

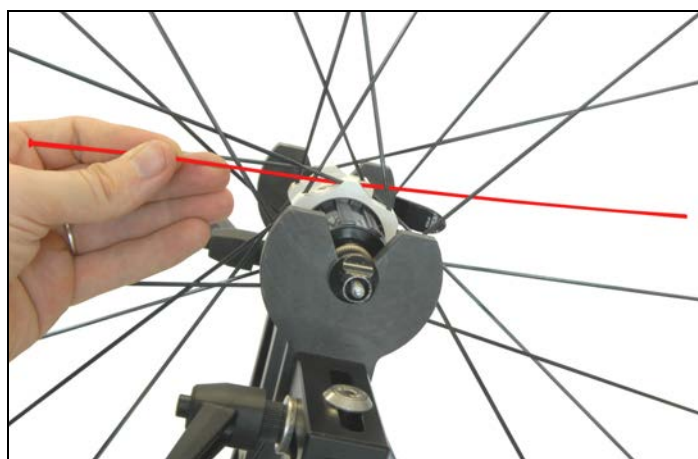

2. Screw on a new nipple.
3. Tighten the spoke.



Closing Steps

Link

True the wheel.

[chap. 5.3, page 39](#)

Mount tire and if necessary rim tape and tube.

Mount the wheel if necessary.

## 5.7 Rebuilding the Wheel [ROAD]

### Preparatory Steps

---

All spokes are available in the correct lengths.

#### 5.7.1 Putting on the Spokes on the Front Wheel

1. Slide all spokes through the spoke holes on the first side of the hub.

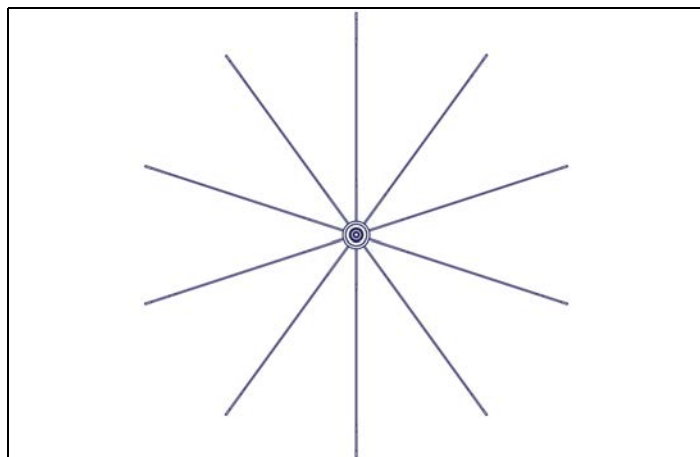

2. Slide all spokes through the spoke holes on the second side of the hub.

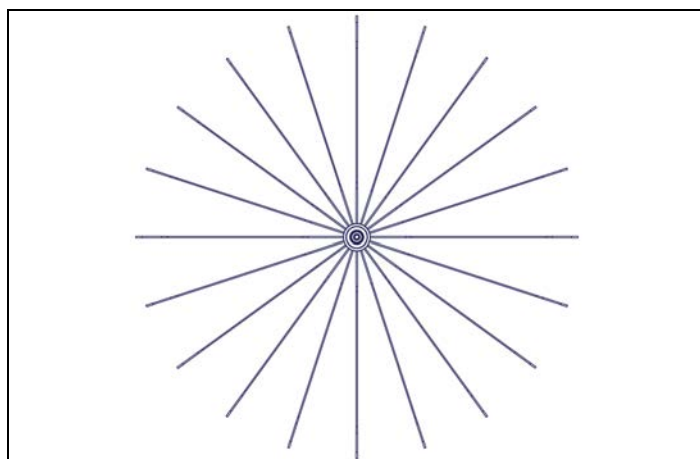

3. Connect the «spoke tree» to the rim (see [Kap.5.7.3, S.61](#)).

## 5.7.2 Putting on the Spokes on the Rear Wheel

General:

The crossing of the spokes must always be like shown in the picture.

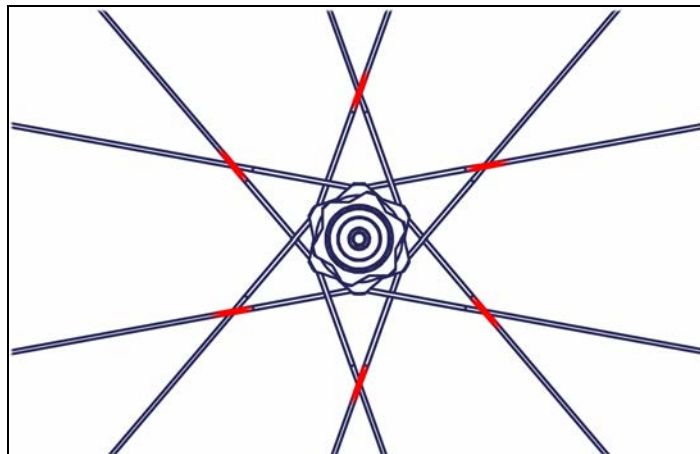

1. Slide all spokes through the spoke holes on the first side of the hub.  
→For easier handling, first put the spokes into the inner side of the hub.

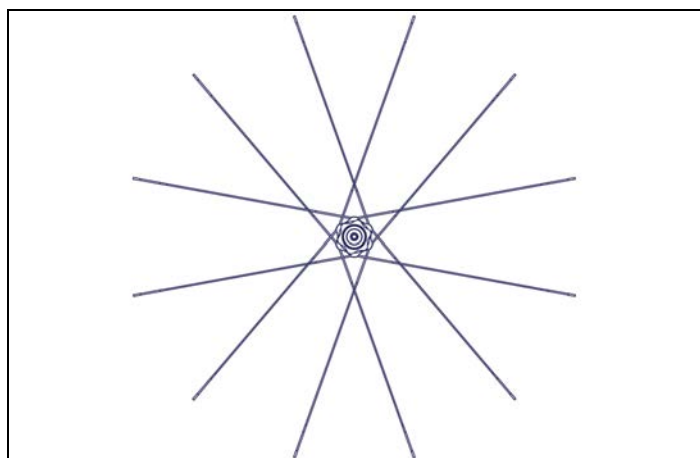

2. Slide all spokes through the spoke holes on the second side of the hub.  
→For easier handling, first put the spokes into the inner side of the hub.

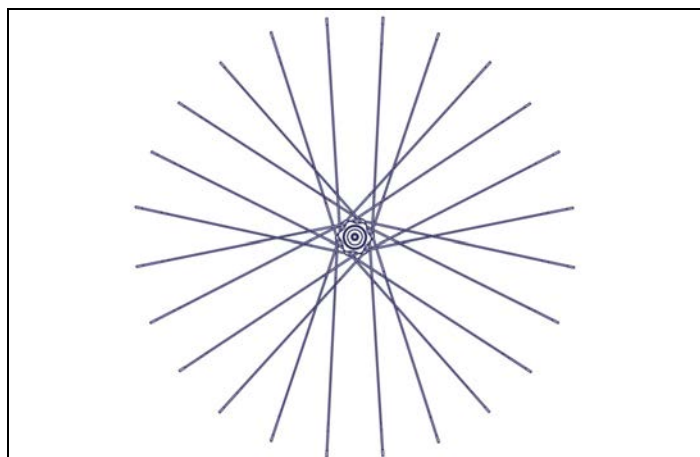

3. Connect the «spoke tree» to the rim (see [chap. 5.7.3, page 61](#)).

### 5.7.3 Connecting the «Spoke Tree» to the Rim

1. Position the «spoke tree» in the way that there is no spoke crossing above the valve hole.  
→ Check the positioning of the stickers on the hub and on the rim.

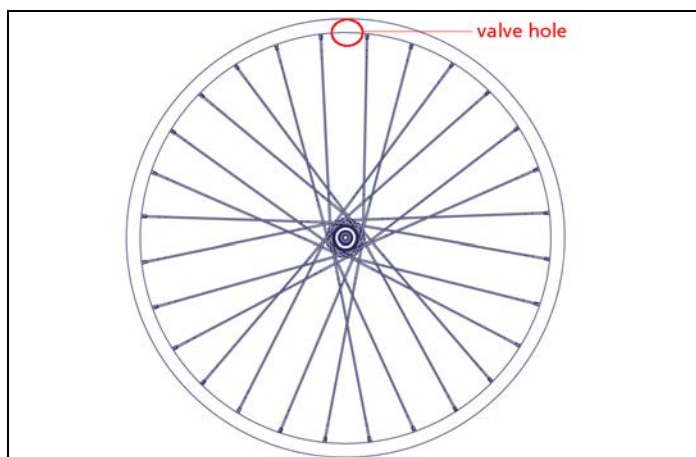

2. Screw the nipple onto the spoke until the thread disappears.
3. Repeat step on all spokes.



## NOTICE

### Risk of damaging the bladed spokes and the nipples!

- Bladed spokes must be hold with the spoke holder while turning the nipple.
- Whenever possible there should be used the universal spoke holder (see [Kap.5.2, S.38](#)) to avoid damages to the spokes. The spoke holder made out of metal (see [Kap.5.2, S.38](#)) should only be used if the universal spoke holder can't be used due to the high torque.
- There are used different spokes types (see [Kap.6.1, S.63](#)). Ensure that the correct tool is being used.
- To avoid damages to the spoke, slide the spoke holder as far as possible in direction of the rim.
- To avoid damages to the nipples, slide the nipple wrench as far as possible onto the nipple.

## Increasing the Spoke Tension

1. Increase the spoke tension (see [chap. 6.1, page 63](#)) by using appropriate tools (see [chap. 5.2, page 38](#)).

Caution: The figure shows a wheel with bladed spokes.



---

### Closing Steps

True the wheel.

### Link

[chap. 5.3, page 39](#)

## 6 Technical Data

Further technical data, like spoke types, spoke lengths etc. can be found in the DT Swiss Techbook at [www.dtswiss.com](http://www.dtswiss.com).

### 6.1 Spoke Tension

		Max. Tolerated Spoke Tension of the Higher Tightened Wheel Side [N]	Min. Tolerated Spoke Tension of the Higher Tightened Wheel Side [N]	Average Spoke Tension of the Higher Tightened Wheel Side [N]
Disc Brake	FW	1 200	950	1 150 - 1 000
	RW	1 300	1 050	1 250 - 1 100
Rim Brake	FW	1 000	800	950 - 850
	RW	1 300	1 050	1 250 - 1 100

### 6.2 Tolerances

Type of Wheel		Horizontal Run Out [mm]	Vertical Run Out [mm]	Off Center (Dish) [mm]
ROAD	RC	0.25	0.5	0.2
	R	0.25	0.3	0.2
MTB	XRC	0.25	0.5	0.3
	XR, XM, EX	0.25	0.3	0.3
	X, M, E	0.3	0.4	0.4



DT Swiss AG  
Längfeldweg 101  
CH - 2504 Biel/Bienne  
E-mail: [mail@dtswiss.com](mailto:mail@dtswiss.com)

DT Swiss, Inc.  
2493 Industrial Blvd.  
USA - Grand Junction, CO 81505  
E-mail: [info@dtswiss-us.com](mailto:info@dtswiss-us.com)

DT Swiss (France) S.A.S.  
Parc d'Activites de la SARREE  
Route de Gourdon  
F - 06620 Le Bar sur Loup  
E-Mail: [service.fr@dtswiss.com](mailto:service.fr@dtswiss.com)

DT Swiss (Asia) Ltd.  
No. 26, 21st Road Industrial Park  
Taichung City  
E-mail: [info@dtswiss-asia.com](mailto:info@dtswiss-asia.com)

[www.dtswiss.com](http://www.dtswiss.com)

Subject to technical alterations, errors  
and  
misprints excepted. All rights reserved.

© by DT Swiss AG