



# M30 BB386 EVO

For M30 Road Cranks

## SAFETY INFORMATION - READ BEFORE RIDE

Since specific tools and experience are necessary for proper installation, it is recommended that the product be installed by a qualified bicycle technician.

Read the service instructions of your crank carefully prior to installing the parts. Loose, worn or damaged parts may cause riding problems and serious injury may occur as a result. If installation and adjustments are not carried out correctly, the chain may come off and this may cause you to fall off the bicycle which could result in serious injury. **Read these instructions carefully, and keep them for later use.**

- Ensure that your BB30/PF30 frame shell is clean. If a BB30 frame, remove the c-clips/bearings so frame shell is empty.
- Conversion BB - Make sure the black O-ring is on the Non-Drive Cup prior to pressing into Non-Drive side.
- Apply **Anti-Seize** to the drive cup threads and smooth taper area before installing.
- Before riding the bicycle, check that there is no play or looseness in the bottom bracket connection. Also, be sure to retighten the crankarms and pedals at periodic intervals.
- If you feel any looseness or 'play' in the bearings, the bottom bracket should be inspected/replaced.
- Be sure to read the instructions for your front chainrings/crank in conjunction with these service instructions.
- **Do not wash the bottom bracket with high-pressure jets of water.**
- For maximum performance it is required to remove and periodically inspect/clean your Praxis Works bottom bracket.
- **Parts are not guaranteed against natural wear or deterioration resulting from normal use.**
- For any questions regarding methods of installation, adjustment, maintenance or operation, please contact a professional bicycle dealer or call Praxis Works.
- Praxis Works assumes no responsibility for damages or injury related to improperly installed components.

**READ THE STEP BY STEP INSTRUCTIONS PROVIDED ON THE OTHER SIDE.**

## WARRANTY

- Praxis Works Bottom Bracket products are warranted to be free from defects in materials or workmanship for two years after original purchase. The warranty is non-transferable and valid to the original purchaser of the product only.
- Any attempt to modify the product in any way such as drilling, grinding or painting will void the warranty.
- This warranty is not valid for "abused" or neglected products, or products that are damaged by improper installation.
- If a defect is found, our entire liability and your sole remedy shall be, at our option, free repair or replacement of the Praxis product.
- Except as expressly required by law, Praxis Works shall not be held liable for any indirect, special, or consequential damages.

THIS WRITTEN EXPRESS WARRANTY IS IN LIEU OF ALL OTHER WARRANTIES, IMPLIED OR EXPRESSED. This warranty gives you specific legal rights, and you may also have other rights which vary state to state. **For more information on warranty policy and instructions for completing a warranty claim, check out the Full Warranty Policy found at our website. [www.praxis-works.com](http://www.praxis-works.com)**

## M30 BB386 EVO Compatibility and Spec

CRANKSET	Compatible with Praxis M30 Based <b>ROAD</b> Cranks
FRAME SHELL	BB386 EVO ROAD Frames
FRONT DERAILLEUR	Braze-on or ST Clamp

## REQUIRED TOOLS

- Bearing Press Tool
- Hammer
- Loctite Superflex Clear
- Headset Cup Removal Tool

## Included Parts

Number	Part	Qty
①	28mm ID X 2mm Dust Cover (stepped cover)	1
②	LEFT/NON-DRIVE 28mm I.D PF Bearing	1
③	Cup Sealing O-ring	1
④	RIGHT/DRIVE 30mm I.D PF Bearing	1
⑤	30mm ID X 1mm Dust Cover	1
⑥	30mm ID X 2mm Dust Cover	1
⑦	Wave Washer	1

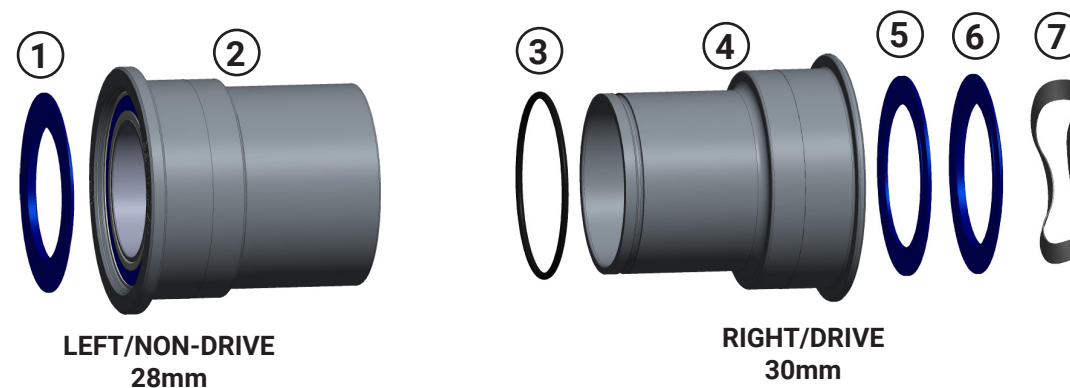

LEFT/NON-DRIVE  
28mm

RIGHT/DRIVE  
30mm

## 1. PREP

**Loctite Superflex RTV Silicone (or similar RTV silicone) is to be used on both Aluminum and Carbon frames**

- 1 Clean the BB shell using a solvent to remove any residual grease

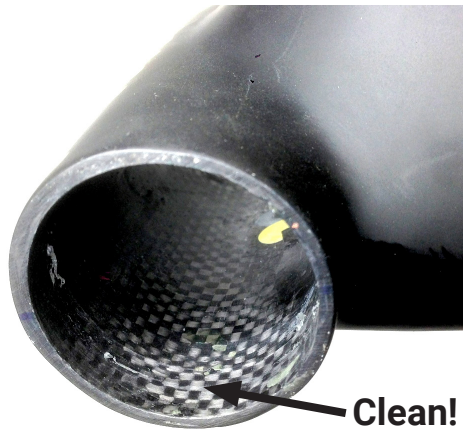

- 2 Use **Loctite Superflex RTV Silicone Adhesive** (Room Temp Vulcanizing) for all frame materials (*Clear or Black RTV*)



- 3 Spread a *thin coat* of silicone around the BB shell and on the BB cup surface as shown.

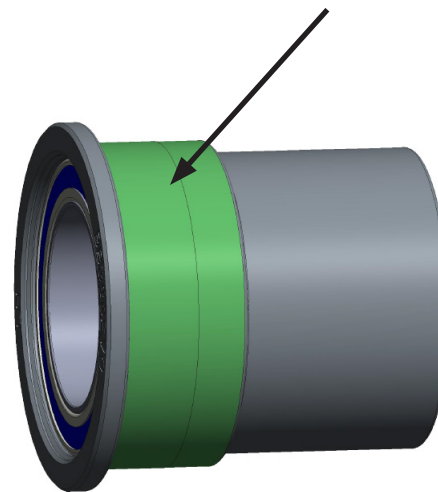

LEFT/Non-Drive BB Cup

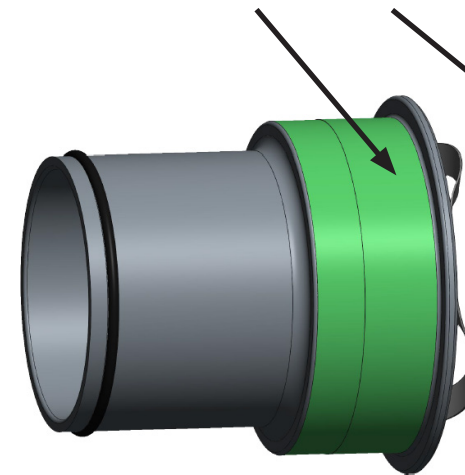

RIGHT/Drive BB Cup

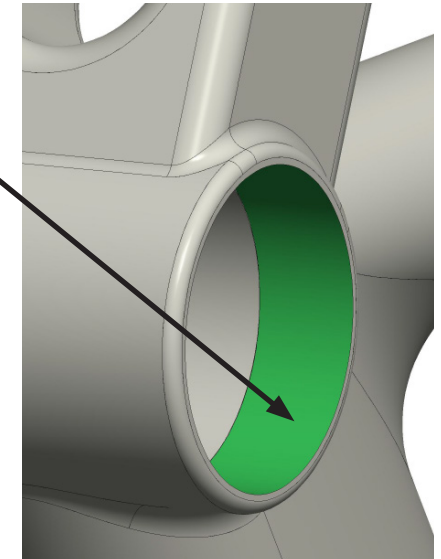

## 2. INSTALL

### Installation Notes

- Press all bearings using a professional press tool.
- Press all bearings flush against the bottom bracket shell.
- **Press one bearing at a time!**

- 1 Press the 28mm ID bearing into the LEFT/Non-Drive side of the frame.
- 2 Then press the 30mm ID bearing into the RIGHT/Drive side of the frame.
- 3 Wait 24hrs for silicone to cure if pressed into carbon BB shell.

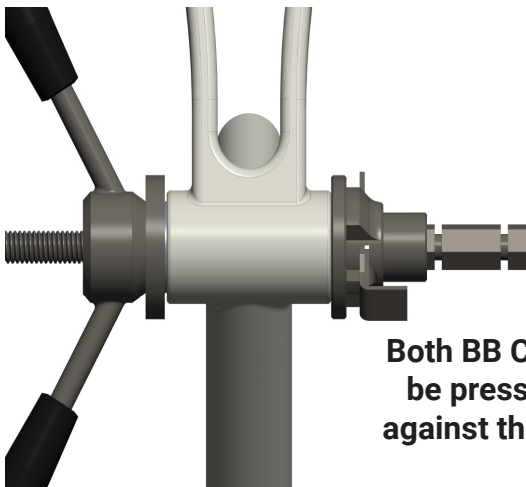

**Both BB Cups must be pressed flush against the BB shell**

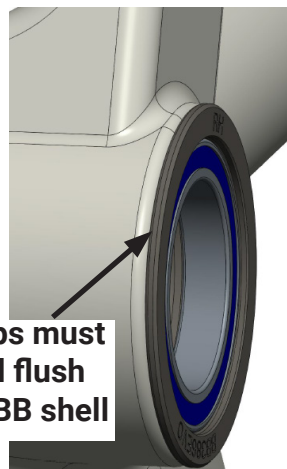

### BB DUST COVER SETUP GRAPHIC

LEFT/NON-DRIVE  
28mm I.D.

Only 1 cover per side!

RIGHT/DRIVE  
30mm I.D.

2mm Cover  
ALL CRANKS  
(Stepped Cover)

28mm

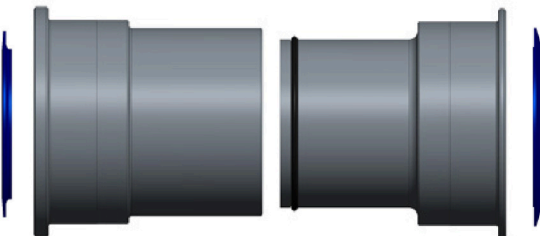

30mm

1mm Cover  
FOR 3-BOLT DM CRANKS ROAD

2mm Cover  
FOR INTEGRATED SPIDER CRANKS ROAD

## REMOVAL

Use **Park Tool RT-1 Headset Removal Tool** or a similar tool to remove BB cups from BB shell.

1. Pull the headset removal tool through the Drive Side cup until you hear two clicks, then hammer out the Drive Side BB Cup.

2. Feed the headset removal tool in from the drive side until it contacts the Non-Drive Side BB Cup, then hammer out the Non-Drive Side Cup.

